

**BOARD OF ZONING APPEALS AGENDA  
CITY OF PIQUA, OHIO  
6:00 P.M. - NOVEMBER 23, 2010  
MUNICIPAL GOVERNMENT COMPLEX  
COMMISSION CHAMBERS - 201 W. WATER STREET**

CALL TO ORDER

ROLL CALL

**SWEARING IN** SHAWN HICKS

MEETING MINUTES August 24, 2010

OLD BUSINESS

None

NEW BUSINESS

1. Resolution BZA 13-10 A petition to variance section 154.081(A) minimum driveway setback to a lot line to allow the installation of a new driveway at 1149 Fisher Drive.
2. Resolution BZA 14-10 A petition to variance section 154.127(G)(2)(a) minimum front yard setback to allow an addition to the existing principal structure at 741 Staunton Street.
3. Resolution BZA 15-10 A petition to variance section 154.081(A) minimum parking lot setback to a lot line to allow the expansion of an existing parking lot at 101 Fox Drive.
4. Resolution BZA 16-10 A petition to variance section 154.028(G)(1) minimum front yard setback to allow the expansion of a parking lot at 101 Fox Drive.
5. Resolution BZA 17-10 A petition to variance section 154.101(D)(2)(5) maximum sign face area (number of panels), minimum setback, and maximum height to allow the replacement of the sign panels on the existing high-rise pole sign at 900 Scott Drive (along I-75).
6. Resolution BZA 18-10 A petition to variance section 154.102(D)(2)(a)(1) maximum number of primary signs at 1300 E. Ash Street.
7. Resolution BZA 19-10 A petition to variance section 154.102(C)(1) maximum area for a wall sign at 1200 E. Ash Street.

OTHER BUSINESS None

ADJOURNMENT

# **BOARD OF ZONING APPEALS**

## **OATH OF OFFICE**

*I, SHAWN HICKS, solemnly swear (or affirm) that I will obey the Constitution and Laws of the United States and of the State of Ohio, that I will in all respects, observe the provisions of the Charter and Ordinances of the City of Piqua, and faithfully discharge the duties of the Board of Zoning Appeals.*

---

*Steve Reindel  
Board of Zoning Appeals*

*Sworn to and subscribed in my presence this 23<sup>rd</sup> day of November, 2010.*

---

*Joni Kakatolis  
Clerk*

CITY OF PIQUA, OHIO  
BOARD OF ZONING APPEALS MEETING MINUTES  
TUESDAY, AUGUST 24, 2010

MUNICIPAL GOVERNMENT COMPLEX - COMMISSION CHAMBERS

**CALL TO ORDER**

At 6:00 Chair, Steve Reindel called the meeting to order. The Chair read the Introductory Statement of BZA Duties and outlined the order of business to be followed. The Chair reviewed the meeting conduct procedures and swore in those persons in attendance. The Chair asked all persons present to stand and raise their right hand. The Chair administered an oath to all persons present to testify before the BZA asking them to swear or affirm to tell the truth, and to acknowledge their intent to abide by the oath administered by stating, "I do" or "opposed". All persons present stood and took the oath to tell the truth with all persons present stating "I do".

**ROLL CALL**

Members Present: Chair, Steve Reindel, Mark Spoltman, Pat Jenkins and Daniel Patrizio.

Members Absent: Jimmy Reedy

Staff Members: Chris Schmiesing, and Joni Kakatolis, Clerk

Attendees: John Henry, 720 Adams St., Piqua, OH 45356  
Penny Cundiff, 720 Adams St., Piqua, OH 45356  
Carla Huber, 715 Roosevelt, Piqua, OH 45356  
Nick Alexander, 713 Roosevelt, Piqua, OH 45356

The Chair administered the Oath of Office to the newest BZA Member, Daniel Patrizio.

**MEETING MINUTES**

A motion to accept the June 22, 2010 meeting minutes was made by Mark Spoltman, seconded by Pat Jenkins. Mr. Reindel, Mr. Spoltman and Mr. Jenkins voted in favor. Mr. Patrizio abstained due to the fact that he is a newly appointment member of the BZA Board.

The motion was carried with a vote of 3-0.

**OLD BUSINESS**

None

**NEW BUSINESS**

**1. Resolution BZA 12-10**

A petition to variance Section 154.025 front yard and side yard setback requirements to allow redevelopment of the lot at 715 S.

CITY OF PIQUA, OHIO  
BOARD OF ZONING APPEALS MEETING MINUTES  
TUESDAY, AUGUST 24, 2010

MUNICIPAL GOVERNMENT COMPLEX - COMMISSION CHAMBERS  
Roosevelt Ave., Piqua, Ohio with non standard setbacks similar to those that currently exist.

The Clerk read the Agenda item.

Mr. Schmiesing presented the Staff Report indicating that the proposed variance if approved, would allow for the redevelopment of the subject location with a new building, parking lot and landscaping. The proposed improvements would replace the existing improvements currently found at the location being utilized by the existing auto repair shop. The proposed setbacks, as shown, satisfy the setback requirements for the B General Business district if not for the property being situated adjacent to residential zoning district. The code required side yard setback is 10 feet and the proposed side yard setback is 6 feet. The code required front yard setback is 25 feet and the proposed front yard setback is 6 feet - inches. The Planning Commission had previously rezoned this property to make possible the continuance of the existing auto repair shop use on the premises. Even with the more restrictive setbacks that are applicable, and despite the irregular shape of the lot, the site layout being proposed is sensitive to the surrounding residential uses. The boundaries shared with residential uses include a 6 foot high chain link fence with screening slats, the building is orientated so that the open side of the building faces away from the surrounding residential uses, and the site design includes green space and other landscaping amenities not currently found at the location. Unlike the existing facility, the proposed parking lot will be curbed and asphalted to reduce dust and better manage site storm water runoff.

Staff recommends that the Board of Zoning Appeals approve the requested variance.

Mr. Jenkins requested some clarification on the drawing submitted to the Board. Mr. Schmiesing indicated that the drawing provided was an older submittal and that the settlement of a court case concerning the exact location of the east lot line will cause the entire building to shift approximately 14 feet to the east so that the building will remain 6 feet off of the actual lot line location as determined by the courts.

Carla Huber presented the Board with the site plan for their review. Mr. Schmiesing reviewed the plan with the Board members and clarified the location of the existing lot line as opposed to the new lot line location.

The applicant, Carla Huber addressed the Board inquiring about asphalt, catch basin and water to the property. Mr. Schmiesing responded explaining to the board the nature of the each of the items and informing the Board that these items related to the plan review

CITY OF PIQUA, OHIO  
BOARD OF ZONING APPEALS MEETING MINUTES  
TUESDAY, AUGUST 24, 2010

MUNICIPAL GOVERNMENT COMPLEX - COMMISSION CHAMBERS

concerns raised by staff that are beyond the purview of the BZA and will be addressed with the applicant in the appropriate setting. Ms. Huber indicated that her father has been trying to build a shop for over 5 years and wants to improve the business. Ms. Huber stated she is very passionate about this project.

The Chair opened the floor for public comment. Penny Cardiff, 720 Adams St., Piqua, Ohio lives adjacent to the property and indicated she is opposed to the building because it will interfere with the view from her property. Ms. Cardiff stated she believes the building will disrupt the adequate supply of light and air into her home and that it will increase the traffic and decreases the value of her property.

Nick Alexander, 713 Roosevelt Ave., Piqua, Ohio addressed the Board in support of the proposed building. Mr. Alexander stated that his residence is located immediately to the north of the Huber's auto repair business and that he has found the business to be a good neighbor.

With no other persons responding to Chairman Reindel's request for public comments the public comment period was closed.

Mr. Spoltman indicated that this is an established business. He indicated that the setback still allows the applicant the use of his property and agrees that this location is a non-standard lot with unique and peculiar circumstances.

Mr. Spoltman made a motion to approve the request to variance Section 154.025 front and side yard setback requirements. The motion was seconded by Pat Jenkins. All Board members voted AYE and Resolution 12-10 was approved with a vote of 4-0.

OTHER BUSINESS

Steve Reindel addressed the resignation of Jimmie Reedy. Mr. Schmiesing provided an update noting that a letter of resignation had been received from Mr. Reedy and that the resignation would be formally acknowledged at the next City Commission meeting at which time the vacancy will be publicly announced and applications will begin to be accepted for the vacant position.

ADJOURNMENT

With no further business to conduct it was moved by Mark Spoltman to adjourn the meeting. The motion was seconded by Pat Jenkins. All present voted AYE and the meeting was adjourned at 6:45 PM.

**Joni Kakatolis**

---

**To:** BZA Members

**Subject:** FW: BZA Minutes

Attached are the August 24, 2010 Meeting Minutes

*Joni Kakatolis  
Legal Assistant  
City of Piqua  
201 W. Water Street  
Piqua, OH 45356  
jkakatolis@piquaoh.org  
937-778-2042*

RESOLUTION No. BZA 13-10

WHEREAS, Larry and Jacquelyn Wiles, owners of the property located at 1149 Fisher Drive, Piqua, Ohio, being in a district zoned R-1 (One-family Residential) have filed a petition to variance Section 154.081(A) minimum driveway setback to a lot line to allow the installation of a new driveway at 11149 Fisher Drive.

§ 154.081 GENERAL REGULATIONS.

(A) All required parking spaces shall be located on the same lot as the use for which they are required, subject to the regulations of the district in which they are located. The minimum setback from a front, side, or rear lot line for a parking lot, parking space or driveway serving a residential use shall be three feet. The minimum setback from a front, side, or rear lot line for a parking lot, parking space or driveway serving any use other than a residential use shall be five feet.

WHEREAS, the Board of Zoning Appeals has considered whether the variance requested:

- Is necessary to permits the owner a reasonable use of the land.
- Is justified due to peculiar exceptions and unusual circumstances found at this location that are not generally found within the neighborhood concerned.
- Will constitute a change in the district map
- Will impair an adequate supply of light and air to adjacent property.
- Will increase the congestion in public streets.
- Will increase the public danger of fire and safety.
- Will materially diminish or impair established property values within the surrounding area.
- Will in any other respect impair the public health, safety, comfort, morals, and welfare of the citizens of the city.

NOW THEREFORE BE IT RESOLVED that \_\_\_\_\_ motioned to approve/deny the request to variance Section 154.081(A) minimum driveway setback to a lot line to allow the installation of a new driveway at 11149 Fisher Drive. The motion was seconded by \_\_\_\_\_ and the request was \_\_\_\_\_ approved/denied with a vote of \_\_\_\_\_ as recorded below.

	AYE	NAY	ABSTAIN	ABSENT
Mr. Shawn Hicks	<input type="checkbox"/>	<input type="checkbox"/>	<input type="checkbox"/>	<input type="checkbox"/>
Mr. Pat Jenkins	<input type="checkbox"/>	<input type="checkbox"/>	<input type="checkbox"/>	<input type="checkbox"/>
Mr. Daniel Patrizio	<input type="checkbox"/>	<input type="checkbox"/>	<input type="checkbox"/>	<input type="checkbox"/>
Mr. Steve Reindel	<input type="checkbox"/>	<input type="checkbox"/>	<input type="checkbox"/>	<input type="checkbox"/>
Mr. Mark Spoltman	<input type="checkbox"/>	<input type="checkbox"/>	<input type="checkbox"/>	<input type="checkbox"/>



## PLANNING AND ZONING

---

Christopher W. Schmiesing – City Planner  
201 West Water Street • Piqua, Ohio 45356  
(937) 778-2049 • FAX (937) 778-5165  
E-Mail: cschmiesing@piquaoh.org

### STAFF REPORT

Date: November 11, 2010  
To: Board of Zoning Appeals Members  
From: Chris Schmiesing, City Planner  
Subject: BZA Resolution 13-10

### GENERAL INFORMATION

Applicant: Larry and Jacquelyn Wiles  
Owner: Larry and Jacquelyn Wiles  
Location: 1149 Fisher Drive  
Zoning: R-1 (One Family Residential)  
Land Use  
Existing: Single story one family dwelling unit  
Proposed: Single story one family dwelling unit and private garage  
Request: A petition to variance section 154.081(A) minimum driveway setback to a lot line to allow the installation of a new driveway.

### DISCUSSION/FINDINGS

The proposed variance if approved will allow for the installation of a new concrete driveway around the east end of the principal structure. The proposed driveway will provide access to a proposed accessory structure private garage to be located to the rear of the principal structure. The proposed driveway will have a side yard setback of 1 foot and the minimum setback required by code is 3 feet.

The zoning code includes sections outlining the powers of the Board of Zoning Appeal's relative to variances and the determinations to be made prior to taking official action in a specific case. The following highlights each of the criteria described in those sections and provides staff's analysis of how this request measures up to those standards.

Section 154.142(C)(2) states, "Powers relative to variances. To hear and decide upon petitions for variances and, subject to the conditions and safeguards deemed appropriate by the Board, *to vary the strict application* of the height, area, setback, or parking requirements to the extent necessary **to permit the owner a reasonable use of the land in those specified instances where there are peculiar exceptions, and unusual circumstances in connection with a specific parcel of land, which circumstances are not generally found within the locality or neighborhood concerned.** Prior to taking action on a variance request, the Board may hold a public hearing. Any variance granted by the Board

## STAFF REPORT

Date: November 11, 2010  
Subject: BZA Resolution 13-10

shall become void if within one year on the date of passage, a building permit has not been issued and construction has not been initiated. “

Is this request necessary to permit the owner a reasonable use of the land?

- and -

Is this request justified due to peculiar exceptions and unusual circumstances found at this location that are not generally found within the neighborhood concerned?

*Staff Analysis: Most of the lots in this neighborhood have a typical 50 foot width. While many have a driveway leading to a detached accessory structure to the rear of the property, this property does not. Other driveways found in this neighborhood also lack the minimum setback required. Therefore it is staff's opinion that the setback variance as requested will allow for a reasonable use of the land.*

Section 154.142(D)(1) states, “Official Action. In exercising the above-mentioned jurisdiction, the Board of Zoning Appeals may reverse, affirm, or modify the order, requirement, decision, or determination appealed and may make any decision as ought to be made. In considering all appeals and petitions within its jurisdiction under this chapter, the Board shall, before making any finding in a specific case, first determine that the proposed change will not constitute a change in the district map and will not impair an adequate supply of light and air to adjacent property, or increase the congestion in public streets, or increase the public danger of fire and safety, or materially diminish or impair established property values within the surrounding area, or in any other respect impair the public health, safety, comfort, morals, and welfare of the citizens of the city. In making a determination, the Board may request information and recommendations from any department of the city.”

Will the request constitute a change in the district map?

*Staff Analysis: This request will not require a change in the zoning map.*

Will this request impair an adequate supply of light and air to adjacent property?

*Staff Analysis: It is unlikely that the proposed construction will impair the supply of light and air to adjacent property.*

Will this request increase the congestion in public streets?

*Staff Analysis: It is unlikely that the proposed construction will increase the congestion in the public streets.*

Will this request increase the public danger of fire and safety?

*Staff Analysis: It is unlikely that the proposed construction will increase the public danger of fire and safety.*

## STAFF REPORT

Date: November 11, 2010  
Subject: BZA Resolution 13-10

Will this request materially diminish or impair established property values within the surrounding area? And, will this request in any other respect impair the public health, safety, comfort, morals, and welfare of the citizens of the city?

*Staff Analysis: It is unlikely that the proposed construction will impair established property values, public health, safety, comfort, morals, or the welfare of the neighborhood, community, or citizens.*

### CONCLUSION

It does not appear that allowing a reduction to the setback requirement for the proposed driveway will have an adverse affect on the surrounding properties. It would appear that the proposed improvements will be consistent and compatible with those already found within the neighborhood concerned.

Based upon the information provided, it is staff's conclusion that authorizing the proposed variance...

- will yield the property owner a reasonable use of the property
- will not result in a substantial deviation from the code requirements
- will not substantially alter the character of the neighborhood or be a detriment to the adjoining properties
- will not adversely affect the delivery of government services
- will not relieve the property owner from conforming to all other applicable standards
- will solve a problem that can not be remedied by other means
- will preserve the spirit and intent of the zoning requirements and serve substantial justice with reference to the circumstances and conditions known to exist within the neighborhood concerned.

### RECOMMENDATION

Staff recommends that the Board of Zoning Appeals **approve** the requested variance.

**STAFF REPORT**

Date: November 11, 2010  
Subject: BZA Resolution 13-10

**VICINITY MAP**

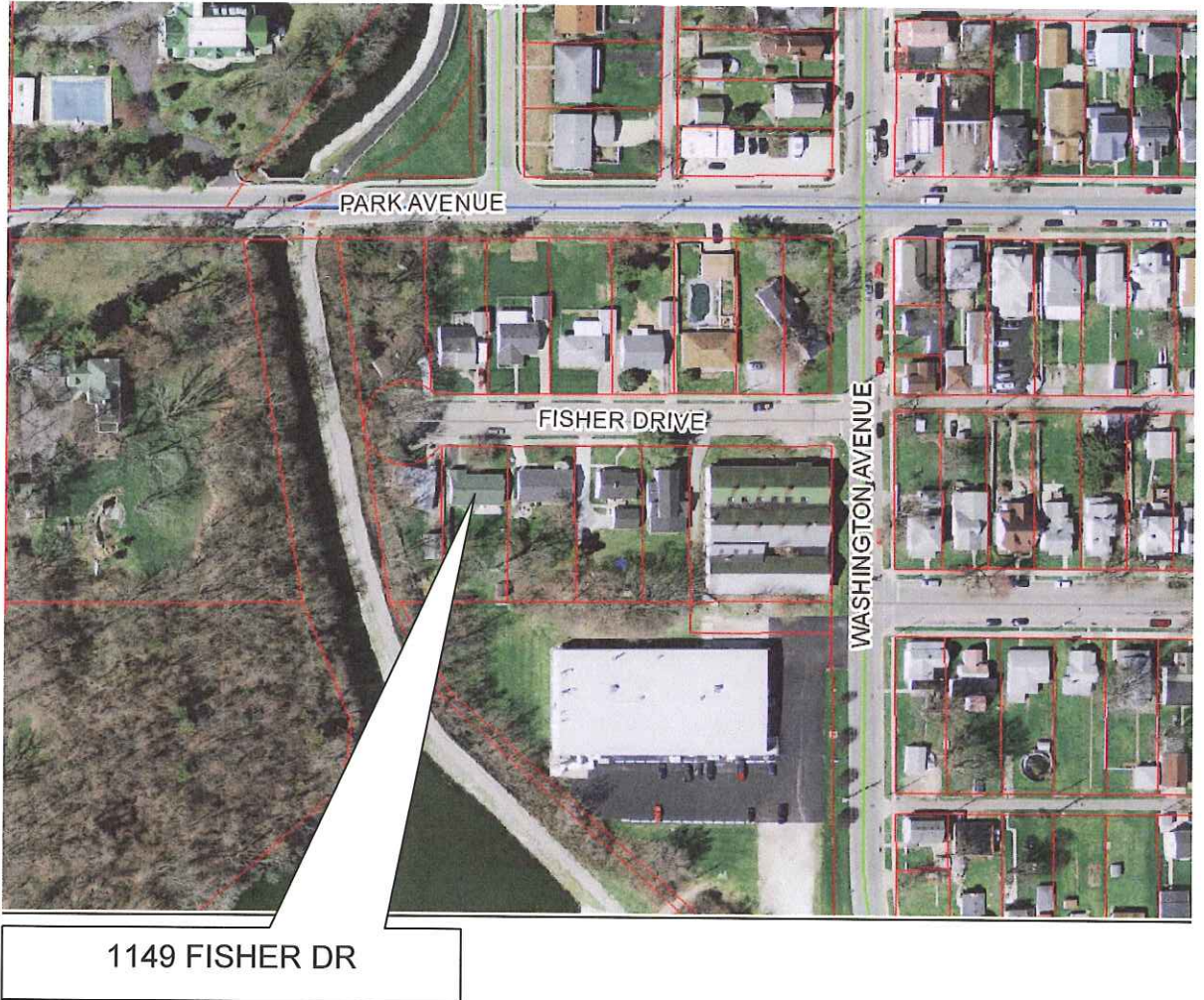

13-10

BOARD OF ZONING APPEALS

APPLICATION REQUESTING A ZONING VARIANCE

-PLEASE TYPE OR PRINT-

APPLICANT NAME Larry and Jacquelyn Wiles  
APPLICANT ADDRESS 1149 Fisher Drive  
CITY Piqua STATE OH ZIP 45356  
PHONE (937) 773-0967  
LEGAL INTEREST OF APPLICANT owner

OWNER NAME same  
BUSINESS NAME \_\_\_\_\_  
OWNER ADDRESS \_\_\_\_\_  
CITY \_\_\_\_\_ STATE \_\_\_\_\_ ZIP \_\_\_\_\_  
PHONE ( \_\_\_\_\_ ) \_\_\_\_\_ - \_\_\_\_\_

PROPERTY LOCATION WHERE VARIANCE IS BEING REQUESTED  
STREET ADDRESS 1149 Fisher Drive  
CITY Piqua STATE Ohio ZIP 45356  
LOT NUMBER N44-058860 ZONING DESIGNATION \_\_\_\_\_

TYPE OF VARIANCE BEING REQUESTED - (CIRCLE ONE) ZONING -OR- SIGN

-CHECK ALL BOXES THAT APPLY-

- ZONING ENFORCEMENT APPEAL
- SPECIAL DRIVEWAY
- HEIGHT VARIANCE ?
- SETBACK VARIANCE
- AREA VARIANCE
- PARKING VARIANCE
- ZONING MAP BOUNDARY LINE
- OTHER

BRIEFLY DESCRIBE VARIANCE REQUEST We are requesting a driveway to access our backyard for the construction of a 2-car garage.

I hereby certify that the proposed request is authorized by the owner of record and agree to conform to all applicable laws of the City of Piqua, Ohio.

SIGNATURE OF OWNER Jacquelyn A. Wiles DATE 10-26-10

SIGNATURE OF APPLICANT Jacquelyn A. Wiles DATE 10-26-10

NOTE - BOTH OWNER AND APPLICANT DATED SIGNATURES IN INK REQUIRED TO PROCESS REQUEST

\*\*\*\*\*OFFICE USE ONLY\*\*\*\*\*

\$25.00 FEE PAID - 25.00 RECEIVED BY - B. Cool

RECEIPT No. - 194929 DATE - 10-28-10

Scale

1" = 15ft.

1149 Fisher Dr.

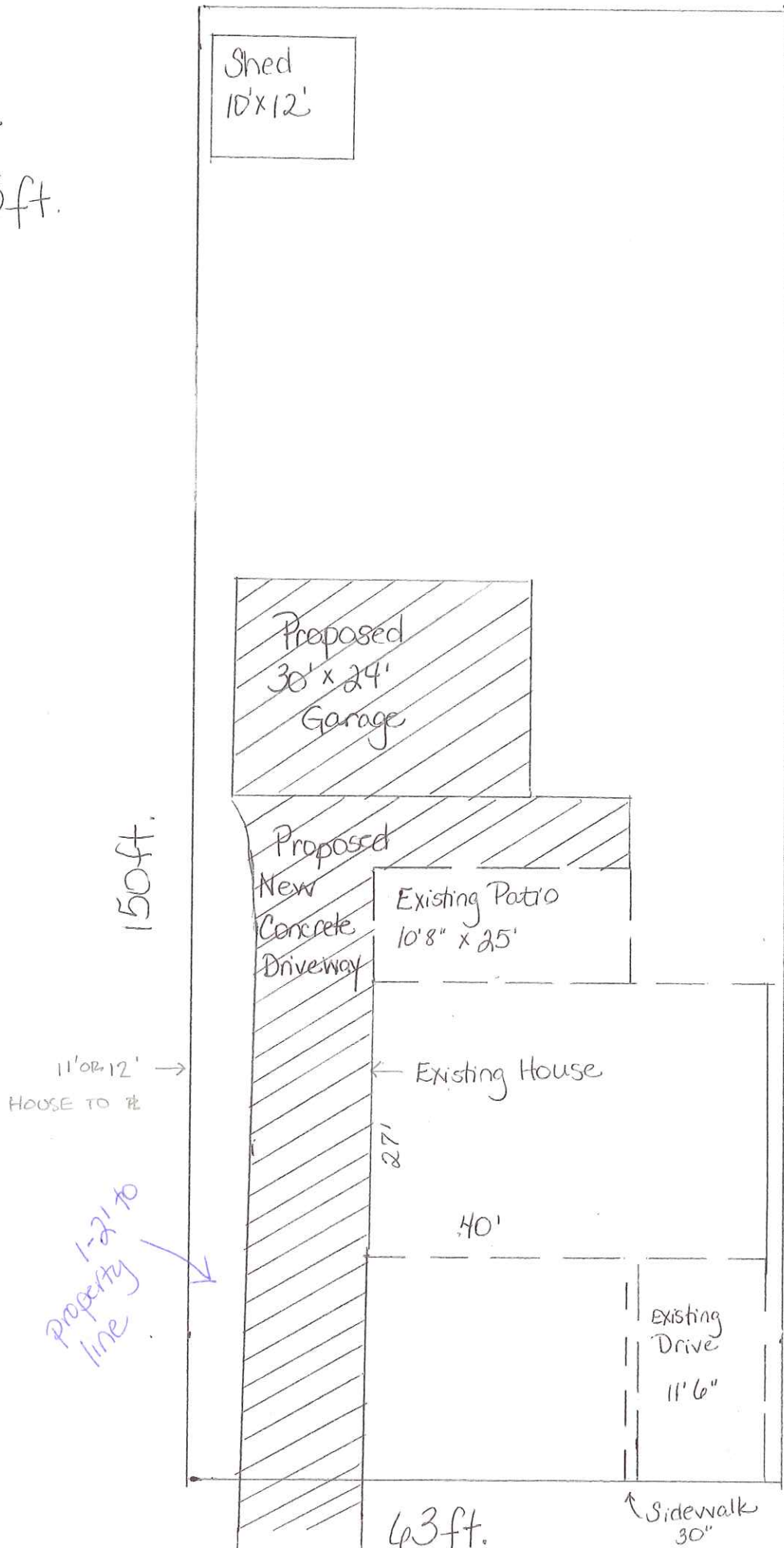

RESOLUTION No. BZA 14-10

WHEREAS, Matt Bushnell, owner of Bushnell's Collision and Restoration located at 741 Staunton Street, Piqua, Ohio, being in a district zoned I-1 (Light Industrial) has filed a petition to variance Section 154.127(G) (2) (a) minimum front yard setback to allow an addition to the existing principal structure at 741 Staunton Street.

§ 154.027 I-1 LIGHT INDUSTRIAL DISTRICT.

(G) Height and area regulations. The maximum height and minimum lot requirements within the I-1 Light Industrial District shall be as follows.

(2) Where an I-1 Industrial District abuts, or is across the street from, a residential district, the following minimum requirements shall apply.

(a) The minimum front yard shall be 50 feet. If loading facilities are located in the front yard, the required front yard shall be 80 feet.

WHEREAS, the Board of Zoning Appeals has considered whether the variance requested:

- Is necessary to permits the owner a reasonable use of the land.
Is justified due to peculiar exceptions and unusual circumstances found at this location that are not generally found within the neighborhood concerned.
Will constitute a change in the district map
Will impair an adequate supply of light and air to adjacent property.
Will increase the congestion in public streets.
Will increase the public danger of fire and safety.
Will materially diminish or impair established property values within the surrounding area.
Will in any other respect impair the public health, safety, comfort, morals, and welfare of the citizens of the city.

NOW THEREFORE BE IT RESOLVED that \_\_\_\_\_ motioned to approve/deny the request to variance Section 154.027 (G) (2) (a) to allow an addition to the existing principal structure at 741 Staunton Street. The motion was seconded by \_\_\_\_\_ and the request was \_\_\_\_\_ approved/denied with a vote of \_\_\_\_\_ as recorded below.

Table with 5 columns: Name, AYE, NAY, ABSTAIN, ABSENT. Rows include Mr. Shawn Hicks, Mr. Pat Jenkins, Mr. Daniel Patrizio, Mr. Steve Reindel, Mr. Mark Spoltman.



## PLANNING AND ZONING

---

Christopher W. Schmiesing – City Planner  
201 West Water Street • Piqua, Ohio 45356  
(937) 778-2049 • FAX (937) 778-5165  
E-Mail: cschmiesing@piquaoh.org

### STAFF REPORT

Date: November 11, 2010  
To: Board of Zoning Appeals Members  
From: Chris Schmiesing, City Planner  
Subject: BZA Resolution 14-10

### GENERAL INFORMATION

Applicant: Bushnell's Collision and Restoration  
Owner: Matt Bushnell  
Location: 741 Staunton Street  
Zoning: I-1 (Light Industrial)  
Land Use  
Existing: Auto Body Repair Shop  
Proposed: Auto Body Repair Shop  
Request: A petition to variance section 154.127(G)(2)(a) minimum front yard setback to allow an addition.

### DISCUSSION/FINDINGS

The proposed variance if approved will allow for an addition to the existing principal structure. The proposed addition would be on the west end of the building and extend 15 feet further towards Staunton Street. The alignment of the west wall of the existing building does not parallel the Staunton Street right of way and therefore the actual setback varies at either end of the building. The front corner nearest to the Statler road is currently 50 feet from the Staunton Street right way and with the proposed addition would be setback only 35 feet. The corner of the building furthest from Statler Street currently has a setback of 70 feet and with the proposed addition the resulting setback would be 55 feet. Because the adjacent property across Staunton Street is zoned residential the required front yard setback for this property is 50 feet.

The zoning code includes sections outlining the powers of the Board of Zoning Appeal's relative to variances and the determinations to be made prior to taking official action in a specific case. The following highlights each of the criteria described in those sections and provides staff's analysis of how this request measures up to those standards.

Section 154.142(C)(2) states, "Powers relative to variances. To hear and decide upon petitions for variances and, subject to the conditions and safeguards deemed appropriate by the Board, *to vary the strict application* of the height, area, setback, or parking requirements to the extent necessary **to permit the owner a reasonable use of the land in those**

## STAFF REPORT

Date: November 11, 2010  
Subject: BZA Resolution 14-10

**specified instances where there are peculiar exceptions, and unusual circumstances in connection with a specific parcel of land, which circumstances are not generally found within the locality or neighborhood concerned.** Prior to taking action on a variance request, the Board may hold a public hearing. Any variance granted by the Board shall become void if within one year on the date of passage, a building permit has not been issued and construction has not been initiated. "

Is this request necessary to permit the owner a reasonable use of the land?

- and -

Is this request justified due to peculiar exceptions and unusual circumstances found at this location that are not generally found within the neighborhood concerned?

*Staff Analysis: Because the Staunton Street and Statler Road alignments are not 90° to one another, the building on this lot is squared up to the Statler road frontage, the resulting setbacks along Staunton Street vary. One end of the proposed building addition would remain in conformance with the applicable setback requirement while the other would not. However, an average of the setback measurements would conform to the minimum setback requirement. Therefore it is staff's opinion that the setback variance as requested will allow for a reasonable use of the land.*

Section 154.142(D)(1) states, "Official Action. In exercising the above-mentioned jurisdiction, the Board of Zoning Appeals may reverse, affirm, or modify the order, requirement, decision, or determination appealed and may make any decision as ought to be made. In considering all appeals and petitions within its jurisdiction under this chapter, the Board shall, before making any finding in a specific case, first determine that the proposed change will not constitute a change in the district map and will not impair an adequate supply of light and air to adjacent property, or increase the congestion in public streets, or increase the public danger of fire and safety, or materially diminish or impair established property values within the surrounding area, or in any other respect impair the public health, safety, comfort, morals, and welfare of the citizens of the city. In making a determination, the Board may request information and recommendations from any department of the city."

Will the request constitute a change in the district map?

*Staff Analysis: This request will not require a change in the zoning map.*

Will this request impair an adequate supply of light and air to adjacent property?

*Staff Analysis: It is unlikely that the proposed construction will impair the supply of light and air to adjacent property.*

Will this request increase the congestion in public streets?

*Staff Analysis: It is unlikely that the proposed construction will increase the congestion in the public streets.*

## STAFF REPORT

Date: November 11, 2010  
Subject: BZA Resolution 14-10

Will this request increase the public danger of fire and safety?

*Staff Analysis: It is unlikely that the proposed construction will increase the public danger of fire and safety.*

Will this request materially diminish or impair established property values within the surrounding area? And, will this request in any other respect impair the public health, safety, comfort, morals, and welfare of the citizens of the city?

*Staff Analysis: It is unlikely that the proposed construction will impair established property values, public health, safety, comfort, morals, or the welfare of the neighborhood, community, or citizens.*

### CONCLUSION

With consideration given to the fact that the proposed building addition will not introduce any new building openings or activities that would alter the affect the building improvement or use thereof has on the adjacent residential properties, and considering that the applicant proposes to add additional landscape plantings around the proposed addition to buffer the nearby residential uses, it does not appear that allowing a reduction to the setback requirement for the proposed addition will have an adverse affect on the surrounding properties. It would appear that the proposed improvements will be consistent and compatible with those already found within the neighborhood concerned.

Based upon the information provided, it is staff's conclusion that authorizing the proposed variance...

- will yield the property owner a reasonable use of the property
- will not result in a substantial deviation from the code requirements
- will not substantially alter the character of the neighborhood or be a detriment to the adjoining properties
- will not adversely affect the delivery of government services
- will not relieve the property owner from conforming to all other applicable standards
- will solve a problem that can not be remedied by other means
- will preserve the spirit and intent of the zoning requirements and serve substantial justice with reference to the circumstances and conditions known to exist within the neighborhood concerned.

### RECOMMENDATION

Staff recommends that the Board of Zoning Appeals **approve** the requested variance.

**STAFF REPORT**

Date: November 11, 2010  
Subject: BZA Resolution 14-10

**VICINITY MAP**



14-10

BOARD OF ZONING APPEALS

APPLICATION REQUESTING A ZONING VARIANCE

-PLEASE TYPE OR PRINT-

APPLICANT NAME Boshnell's Collision & Restoration  
APPLICANT ADDRESS 741 Staunton St  
CITY Piqua STATE Ohio ZIP 45356  
PHONE (937) 778-8655  
LEGAL INTEREST OF APPLICANT OWNER

OWNER NAME Matt Boshnell  
BUSINESS NAME Boshnell's Collision & Restoration  
OWNER ADDRESS 4454 W. Demming Rd.  
CITY Piqua STATE OHIO ZIP 45356  
PHONE (937) 418-2728

PROPERTY LOCATION WHERE VARIANCE IS BEING REQUESTED  
STREET ADDRESS 741 Staunton St  
CITY Piqua STATE Ohio ZIP 45356  
LOT NUMBER ? ZONING DESIGNATION ? I-1

TYPE OF VARIANCE BEING REQUESTED --(CIRCLE ONE) ZONING --OR-- SIGN

-CHECK ALL BOXES THAT APPLY-

- ZONING ENFORCEMENT APPEAL
- SPECIAL DRIVEWAY
- HEIGHT VARIANCE
- SETBACK VARIANCE
- AREA VARIANCE
- PARKING VARIANCE
- ZONING MAP BOUNDARY LINE
- OTHER

BRIEFLY DESCRIBE VARIANCE REQUEST wish to add 15ft out on our west end one corner of building will be over set back

I hereby certify that the proposed request is authorized by the owner of record and agree to conform to all applicable laws of the City of Piqua, Ohio.

SIGNATURE OF OWNER [Signature] DATE 11/1/2010

SIGNATURE OF APPLICANT [Signature] DATE 11/1/2010





NOTE - BOTH OWNER AND APPLICANT DATED SIGNATURES IN INK REQUIRED TO PROCESS REQUEST

\*\*\*\*\*OFFICE USE ONLY\*\*\*\*\*

\$25.00 FEE PAID - 25.00 RECEIVED BY - B Cool

RECEIPT No. - 194932 DATE - 11-3-10

# Zoning Appeals App.

-  Existing Concrete
-  Bushes Existing Trees
-  Fence
-  50ft setback



New Addition

1. Less than 1/2 of Building is over Set Back line

2. Will Put in New Landscaping in Front of addition  
New Landscaping Bushes ETC.

3. New Addition has no door exterior so not a noise or driving area

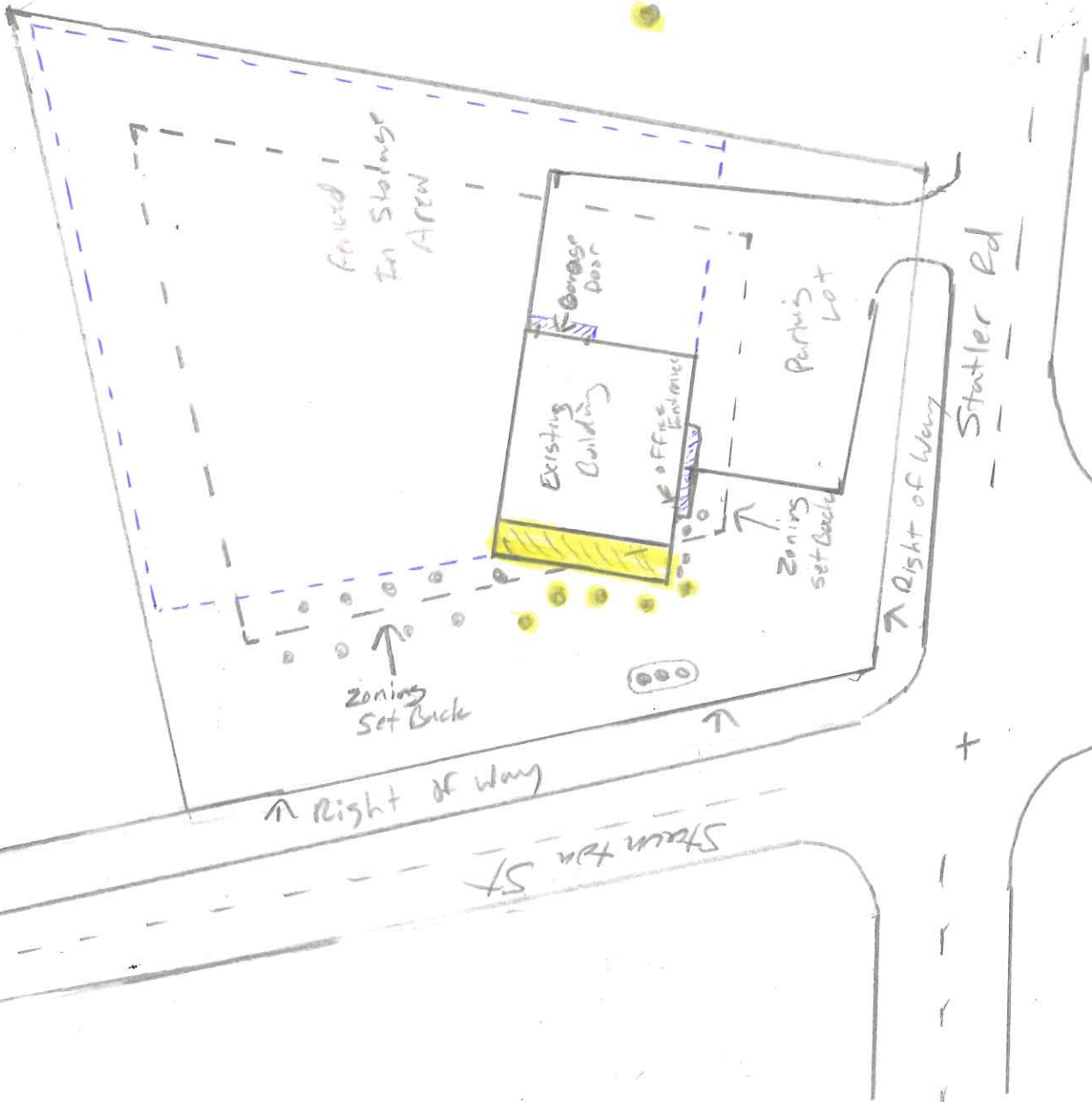

RESOLUTION No. BZA 15-10

WHEREAS, Nick Miller on behalf of Jeff Meyer, owner of Midwest Maintenance, Inc. located at 101 Fox Drive, Piqua, Ohio being in a district zoned I-2 (Heavy Industrial) has filed a petition to variance Section 154.081(A) minimum parking lot setback to a lot line to allow the expansion of an existing parking lot at 101 Fox Drive.

§ 154.081 GENERAL REGULATIONS.

(A) All required parking spaces shall be located on the same lot as the use for which they are required, subject to the regulations of the district in which they are located. The minimum setback from a front, side, or rear lot line for a parking lot, parking space or driveway serving a residential use shall be three feet. The minimum setback from a front, side, or rear lot line for a parking lot, parking space or driveway serving any use other than a residential use shall be five feet.

WHEREAS, the Board of Zoning Appeals has considered whether the variance requested:

- Is necessary to permits the owner a reasonable use of the land.
- Is justified due to peculiar exceptions and unusual circumstances found at this location that are not generally found within the neighborhood concerned.
- Will constitute a change in the district map
- Will impair an adequate supply of light and air to adjacent property.
- Will increase the congestion in public streets.
- Will increase the public danger of fire and safety.
- Will materially diminish or impair established property values within the surrounding area.
- Will in any other respect impair the public health, safety, comfort, morals, and welfare of the citizens of the city.

NOW THEREFORE BE IT RESOLVED that \_\_\_\_\_ motioned to approve/deny the request to variance Section 154.081(A) to allow the expansion of an existing parking lot located at 101 Fox Drive. The motion was seconded by \_\_\_\_\_ and the request was \_\_\_\_\_ approved/denied with a vote of \_\_\_\_\_ as recorded below.

	AYE	NAY	ABSTAIN	ABSENT
Mr. Shawn Hicks	<input type="checkbox"/>	<input type="checkbox"/>	<input type="checkbox"/>	<input type="checkbox"/>
Mr. Pat Jenkins	<input type="checkbox"/>	<input type="checkbox"/>	<input type="checkbox"/>	<input type="checkbox"/>
Mr. Daniel Patrizio	<input type="checkbox"/>	<input type="checkbox"/>	<input type="checkbox"/>	<input type="checkbox"/>
Mr. Steve Reindel	<input type="checkbox"/>	<input type="checkbox"/>	<input type="checkbox"/>	<input type="checkbox"/>
Mr. Mark Spoltman	<input type="checkbox"/>	<input type="checkbox"/>	<input type="checkbox"/>	<input type="checkbox"/>

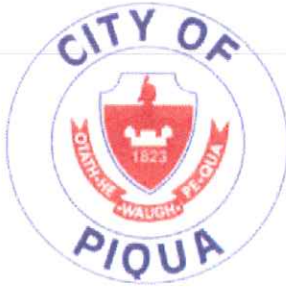

## PLANNING AND ZONING

Christopher W. Schmiesing – City Planner  
201 West Water Street • Piqua, Ohio 45356  
(937) 778-2049 • FAX (937) 778-5165  
E-Mail: cschmiesing@piquaoh.org

### STAFF REPORT

Date: November 11, 2010  
To: Board of Zoning Appeals Members  
From: Chris Schmiesing, City Planner  
Subject: BZA Resolution 15-10

### GENERAL INFORMATION

Applicant: Nick Miller  
Owner: Midwest Maintenance inc.  
Location: 101 Fox Drive  
Zoning: I-2 (Heavy Industrial)  
Land Use  
Existing: Construction trades and contractor office  
Proposed: Construction trades and contractor office  
Request: A petition to variance section 154.081(A) minimum parking lot setback to a lot line to allow the expansion of an existing parking lot.

### DISCUSSION/FINDINGS

The proposed variance if approved will allow for an expansion of the existing parking lot. The proposed expansion will extend the existing pavement edge further to the north along the west lot line to create an additional 7 parking spaces in this area. The new pavement edge will match the existing pavement edge alignment which is setback 2.25 feet from the side lot line. The zoning code requires a minimum setback of 5 feet.

The zoning code includes sections outlining the powers of the Board of Zoning Appeal's relative to variances and the determinations to be made prior to taking official action in a specific case. The following highlights each of the criteria described in those sections and provides staff's analysis of how this request measures up to those standards.

Section 154.142(C)(2) states, "Powers relative to variances. To hear and decide upon petitions for variances and, subject to the conditions and safeguards deemed appropriate by the Board, *to vary the strict application* of the height, area, setback, or parking requirements to the extent necessary **to permit the owner a reasonable use of the land in those specified instances where there are peculiar exceptions, and unusual circumstances in connection with a specific parcel of land, which circumstances are not generally found within the locality or neighborhood concerned.** Prior to taking action on a variance request, the Board may hold a public hearing. Any variance granted by the Board

## STAFF REPORT

Date: November 11, 2010  
Subject: BZA Resolution 15-10

shall become void if within one year on the date of passage, a building permit has not been issued and construction has not been initiated. “

Is this request necessary to permit the owner a reasonable use of the land?

- and -

Is this request justified due to peculiar exceptions and unusual circumstances found at this location that are not generally found within the neighborhood concerned?

*Staff Analysis: The proposed edge of pavement is designed to match the existing edge of pavement alignment. If the pavement were shifted to achieve the code required setback dimension the width of the adjacent maneuvering lane, which also serves as the primary entrance for the large construction equipment that comes and goes from this site, would be reduced in width to a minimum standard. This could potential result in vehicles having difficulty maneuvering through this area. The existing improvements found at this site limit design alternatives that might otherwise achieve the code specified setback and allow the property owner to add the additional parking that is desired. Therefore it is staff's opinion that the setback variance as requested will allow for a reasonable use of the land.*

Section 154.142(D)(1) states, “Official Action. In exercising the above-mentioned jurisdiction, the Board of Zoning Appeals may reverse, affirm, or modify the order, requirement, decision, or determination appealed and may make any decision as ought to be made. In considering all appeals and petitions within its jurisdiction under this chapter, the Board shall, before making any finding in a specific case, first determine that the proposed change will not constitute a change in the district map and will not impair an adequate supply of light and air to adjacent property, or increase the congestion in public streets, or increase the public danger of fire and safety, or materially diminish or impair established property values within the surrounding area, or in any other respect impair the public health, safety, comfort, morals, and welfare of the citizens of the city. In making a determination, the Board may request information and recommendations from any department of the city.”

Will the request constitute a change in the district map?

*Staff Analysis: This request will not require a change in the zoning map.*

Will this request impair an adequate supply of light and air to adjacent property?

*Staff Analysis: It is unlikely that the proposed construction will impair the supply of light and air to adjacent property.*

Will this request increase the congestion in public streets?

*Staff Analysis: It is unlikely that the proposed construction will increase the congestion in the public streets.*

## STAFF REPORT

Date: November 11, 2010  
Subject: BZA Resolution 15-10

Will this request increase the public danger of fire and safety?

*Staff Analysis: It is unlikely that the proposed construction will increase the public danger of fire and safety.*

Will this request materially diminish or impair established property values within the surrounding area? And, will this request in any other respect impair the public health, safety, comfort, morals, and welfare of the citizens of the city?

*Staff Analysis: It is unlikely that the proposed construction will impair established property values, public health, safety, comfort, morals, or the welfare of the neighborhood, community, or citizens.*

### CONCLUSION

The proposed improvements attempt to conform to the applicable standards while also respecting the design and configuration of the existing improvements found at this site. There are no discernible issues with the proposed reduced setback that will result in having an adverse affect on the neighborhood concerned.

Based upon the information provided, it is staff's conclusion that authorizing the proposed variance...

- will yield the property owner a reasonable use of the property
- will not result in a substantial deviation from the code requirements
- will not substantially alter the character of the neighborhood or be a detriment to the adjoining properties
- will not adversely affect the delivery of government services
- will not relieve the property owner from conforming to all other applicable standards
- will solve a problem that can not be remedied by other means
- will preserve the spirit and intent of the zoning requirements and serve substantial justice with reference to the circumstances and conditions known to exist within the neighborhood concerned.

### RECOMMENDATION

Staff recommends that the Board of Zoning Appeals **approve** the requested variance.

**STAFF REPORT**

Date: November 11, 2010  
Subject: BZA Resolution 15-10

**VICINITY MAP**



DRIVE

101 FOX DRIVE

**RESOLUTION No. BZA 16-10**

WHEREAS, Nick Miller on behalf of Jeff Meyer, owner of Midwest Maintenance, Inc. located at 101 Fox Drive, Piqua, Ohio being in a district zoned I-2 (Heavy Industrial) has filed a petition to variance Section 154.028(G)(1) minimum front yard setback to allow the expansion of a parking lot at 101 Fox Drive.

(G) *Height and area regulations.* The maximum height and minimum lot requirements within the I-2 Heavy Industrial District shall be as follows.

(1) General requirements within this district shall be as follows.

Minimum lot area	None
Minimum lot frontage	None
Minimum front yard setback	25 feet
Minimum side yard setback	15 feet
Minimum rear yard setback	15 feet or 30 feet if abutting an alley.
Maximum height	40 feet

WHEREAS, the Board of Zoning Appeals has considered whether the variance requested:

- Is necessary to permits the owner a reasonable use of the land.
- Is justified due to peculiar exceptions and unusual circumstances found at this location that are not generally found within the neighborhood concerned.
- Will constitute a change in the district map
- Will impair an adequate supply of light and air to adjacent property.
- Will increase the congestion in public streets.
- Will increase the public danger of fire and safety.
- Will materially diminish or impair established property values within the surrounding area.
- Will in any other respect impair the public health, safety, comfort, morals, and welfare of the citizens of the city.

NOW THEREFORE BE IT RESOLVED that \_\_\_\_\_ motioned to **approve/deny** the request to variance Section 154.028(G)(1) to allow the expansion of a parking lot located at 101 Fox Drive. The motion was seconded by \_\_\_\_\_ and the request was \_\_\_\_\_ **approved/denied** with a vote of \_\_\_\_\_ as recorded below.

	AYE	NAY	ABSTAIN	ABSENT
Mr. Shawn Hicks	<input type="checkbox"/>	<input type="checkbox"/>	<input type="checkbox"/>	<input type="checkbox"/>
Mr. Pat Jenkins	<input type="checkbox"/>	<input type="checkbox"/>	<input type="checkbox"/>	<input type="checkbox"/>
Mr. Daniel Patrizio	<input type="checkbox"/>	<input type="checkbox"/>	<input type="checkbox"/>	<input type="checkbox"/>
Mr. Steve Reindel	<input type="checkbox"/>	<input type="checkbox"/>	<input type="checkbox"/>	<input type="checkbox"/>
Mr. Mark Spoltman	<input type="checkbox"/>	<input type="checkbox"/>	<input type="checkbox"/>	<input type="checkbox"/>



## PLANNING AND ZONING

Christopher W. Schmiesing – City Planner  
201 West Water Street • Piqua, Ohio 45356  
(937) 778-2049 • FAX (937) 778-5165  
E-Mail: cschmiesing@piquaoh.org

### STAFF REPORT

Date: November 11, 2010  
To: Board of Zoning Appeals Members  
From: Chris Schmiesing, City Planner  
Subject: BZA Resolution 16-10

### GENERAL INFORMATION

Applicant: Nick Miller  
Owner: Midwest Maintenance inc.  
Location: 101 Fox Drive  
Zoning: I-2 (Heavy Industrial)  
Land Use  
Existing: Construction trades and contractor office  
Proposed: Construction trades and contractor office  
Request: A petition to variance section 154.028(G)(1) minimum front yard setback to allow the expansion of a parking lot.

### DISCUSSION/FINDINGS

The proposed variance if approved will allow for the expansion of a parking lot into a required front yard setback area. The proposed parking lot improvements will be setback 20 feet from the front lot line and the front yard area will be planted with trees and other landscaping. The zoning code requires a minimum front yard setback of 25 feet.

The zoning code includes sections outlining the powers of the Board of Zoning Appeal's relative to variances and the determinations to be made prior to taking official action in a specific case. The following highlights each of the criteria described in those sections and provides staff's analysis of how this request measures up to those standards.

Section 154.142(C)(2) states, "Powers relative to variances. To hear and decide upon petitions for variances and, subject to the conditions and safeguards deemed appropriate by the Board, *to vary the strict application* of the height, area, setback, or parking requirements to the extent necessary **to permit the owner a reasonable use of the land in those specified instances where there are peculiar exceptions, and unusual circumstances in connection with a specific parcel of land, which circumstances are not generally found within the locality or neighborhood concerned.** Prior to taking action on a variance request, the Board may hold a public hearing. Any variance granted by the Board

## STAFF REPORT

Date: November 11, 2010  
Subject: BZA Resolution 16-10

shall become void if within one year on the date of passage, a building permit has not been issued and construction has not been initiated. “

Is this request necessary to permit the owner a reasonable use of the land?

- and -

Is this request justified due to peculiar exceptions and unusual circumstances found at this location that are not generally found within the neighborhood concerned?

*Staff Analysis: The proposed reduction to the front yard setback area is not unlike the reduced front yard setback areas found at other properties within the neighborhood concerned. The applicant proposes to provide tree plantings and other vegetation in the front yard area that will remain. The remainder of the site is built out and there is no other location available for the proposed improvements. Therefore it is staff's opinion that the setback variance as requested will allow for a reasonable use of the land.*

Section 154.142(D)(1) states, “Official Action. In exercising the above-mentioned jurisdiction, the Board of Zoning Appeals may reverse, affirm, or modify the order, requirement, decision, or determination appealed and may make any decision as ought to be made. In considering all appeals and petitions within its jurisdiction under this chapter, the Board shall, before making any finding in a specific case, first determine that the proposed change will not constitute a change in the district map and will not impair an adequate supply of light and air to adjacent property, or increase the congestion in public streets, or increase the public danger of fire and safety, or materially diminish or impair established property values within the surrounding area, or in any other respect impair the public health, safety, comfort, morals, and welfare of the citizens of the city. In making a determination, the Board may request information and recommendations from any department of the city.”

Will the request constitute a change in the district map?

*Staff Analysis: This request will not require a change in the zoning map.*

Will this request impair an adequate supply of light and air to adjacent property?

*Staff Analysis: It is unlikely that the proposed construction will impair the supply of light and air to adjacent property.*

Will this request increase the congestion in public streets?

*Staff Analysis: It is unlikely that the proposed construction will increase the congestion in the public streets.*

Will this request increase the public danger of fire and safety?

*Staff Analysis: It is unlikely that the proposed construction will increase the public danger of fire and safety.*

## STAFF REPORT

Date: November 11, 2010  
Subject: BZA Resolution 16-10

Will this request materially diminish or impair established property values within the surrounding area? And, will this request in any other respect impair the public health, safety, comfort, morals, and welfare of the citizens of the city?

*Staff Analysis: It is unlikely that the proposed construction will impair established property values, public health, safety, comfort, morals, or the welfare of the neighborhood, community, or citizens.*

### CONCLUSION

The proposed improvements attempt to conform to the applicable standards while also maximizing the available building envelope found at this location. Parking lot improvements located in front yard setback areas are common within the neighborhood concerned. The planned landscaping in the front yard area will minimize the visual impact of the proposed improvements and enhance the overall aesthetics of the site.

Based upon the information provided, it is staff's conclusion that authorizing the proposed variance...

- will yield the property owner a reasonable use of the property
- will not result in a substantial deviation from the code requirements
- will not substantially alter the character of the neighborhood or be a detriment to the adjoining properties
- will not adversely affect the delivery of government services
- will not relieve the property owner from conforming to all other applicable standards
- will solve a problem that can not be remedied by other means
- will preserve the spirit and intent of the zoning requirements and serve substantial justice with reference to the circumstances and conditions known to exist within the neighborhood concerned.

### RECOMMENDATION

Staff recommends that the Board of Zoning Appeals **approve** the requested variance.

**STAFF REPORT**

Date: November 11, 2010  
Subject: BZA Resolution 16-10

**VICINITY MAP**



15-10  
16-10

Chris Schmiesing, City Planner  
City of Piqua  
Development Department  
201 W. Water Street  
Piqua, OH 45356

Date: November 1, 2010

Re: Midwest Maintenance Building/Site Additions (Parking Variance Request)

Chris,  
Included for your review and consideration are 8 copies (8 1/2" x 11") of the proposed building/site additions proposed by Midwest Maintenance, Inc. Also included is an application and check for the BZA requested variance for the parking.

As shown, existing parking along the west side is 2 1/4' off the property line. We are requesting a variance for the continuation of that parking for 8 additional parking stalls.

Parking along the north side is shown at 20' off the R/W. Upon reviewing your codes, it appears this is within the allowable area. If this is not correct, then we are requesting that it be included with the BZA request-please advise.

Thanks,



Nick Miller, PE, PS

BOARD OF ZONING APPEALS

APPLICATION REQUESTING A ZONING VARIANCE

-PLEASE TYPE OR PRINT-

APPLICANT NAME Nick Miller  
APPLICANT ADDRESS 2201 Patterson Halpin Rd.  
CITY Piqua STATE OH ZIP 45356  
PHONE (937) 773-8578  
LEGAL INTEREST OF APPLICANT Site Engineer

OWNER NAME Jeff Meyer  
BUSINESS NAME Midwest Maintenance, Inc.  
OWNER ADDRESS 101 Fox Drive  
CITY Piqua STATE OH ZIP 45356  
PHONE (937) 773-9236

PROPERTY LOCATION WHERE VARIANCE IS BEING REQUESTED  
STREET ADDRESS 101 Fox Drive  
CITY Piqua STATE Ohio ZIP 45356  
LOT NUMBER pt. lot 7517 ZONING DESIGNATION I-2

TYPE OF VARIANCE BEING REQUESTED -(CIRCLE ONE) ZONING -OR- SIGN

-CHECK ALL BOXES THAT APPLY-

- ZONING ENFORCEMENT APPEAL
- SPECIAL DRIVEWAY
- HEIGHT VARIANCE
- SETBACK VARIANCE
- AREA VARIANCE
- PARKING VARIANCE
- ZONING MAP BOUNDARY LINE
- OTHER

BRIEFLY DESCRIBE VARIANCE REQUEST 2 1/4' setback on west side for parking, rather than 5' that is req'd. Matches existing parking

I hereby certify that the proposed request is authorized by the owner of record and agree to conform to all applicable laws of the City of Piqua, Ohio.

SIGNATURE OF OWNER W. Jeff Meyer DATE 10/30/10

SIGNATURE OF APPLICANT Nick Miller DATE 10/30/10

NOTE - BOTH OWNER AND APPLICANT DATED SIGNATURES IN INK REQUIRED TO PROCESS REQUEST

\*\*\*\*\*OFFICE USE ONLY\*\*\*\*\*

\$25.00 FEE PAID - 25.00 RECEIVED BY [Signature]

RECEIPT No. - 194930 DATE - 11-1-10

Ex. R/W

CL FOX DRIVE (60' R/W)

EX. CURB

EX. CONC.

EX. CONC. (REPLACE)

EX. R/W

209.99'

20' R/W TO PARKING

24'

24'



EX. ASPHALT

EX. GRAVEL DRIVE

EX. CONC.



345.75'

0' TYP.

NEW 1&2 STORY  
NEW 2ND STORY ADDITION

EX. BUILDING

306.80'

2 1/4' PARKING TO PL  
VARIANCE REQUEST MATCHES EXISTING PARKING WEST SIDE

82' EX.

20'

27'

20'

remove

NEW 20' GATE

EX. BUILDING

MIDWEST MAINTENANCE, INC.  
101 FOX DRIVE

65' EX.

5' PARKING TO PL

NEW RETAINING WALL

Canopy

20'

27'

10'

30'

EX. GATE REMOVE

EX. GATE

EX. ASPHALT

EX. GRAVEL LOT

REPRESENTS NEW PARKING PROPOSED



215.16'

OWNER/NAME

MIDWEST MAINTENANCE, INC.  
101 FOX DRIVE Piqua, OH 45356 773-9236

SITE ENGINEER

NICK MILLER, PE, PS  
2201 PATTERSON HALPIN ROAD Piqua, OH 45356 773-9236

PROJECT NAME

MIDWEST MAINTENANCE BUILDING/SITE ADDITIONS

**RESOLUTION No. BZA 17-10**

WHEREAS, Jim Bond with National Illumination & Sign on behalf of Marathon Oil, LLC located at 900 Scott Drive, Piqua, Ohio being in a district zoned B (General Business) has filed a petition to variance Section 154.101(D)(2)(5) maximum sign face area (number of panels), minimum setback, and maximum height to allow the replacement of the sign panels on the existing high-rise pole sign at 900 Scott Drive (along I-75).

**§ 154.101 PERMANENT; DETACHED SIGNS.**

(D) *Other regulations.*

(2) *Number of signs.*

(a) The maximum allowable number of primary permanent detached signs shall be as follows:

5. In addition to, but not in lieu of, the permanent detached sign allowance provided by § 154.101(D)(2)(a)(1) and (2) of this code, each lot within 1,500 feet of the centerline of Interstate 75 shall be permitted one pole sign per lot or lots occupied by the same principal, special, or nonconforming use to which the sign is accessory, provided the sign face area does not exceed 200 square feet, the sign height does not exceed 80 feet, and the minimum setback to all lot lines is 20 feet. This sign may be used as a joint identification sign.

WHEREAS, the Board of Zoning Appeals has considered whether the variance requested:

- Is necessary to permits the owner a reasonable use of the land.
- Is justified due to peculiar exceptions and unusual circumstances found at this location that are not generally found within the neighborhood concerned.
- Will constitute a change in the district map
- Will impair an adequate supply of light and air to adjacent property.
- Will increase the congestion in public streets.
- Will increase the public danger of fire and safety.
- Will materially diminish or impair established property values within the surrounding area.
- Will in any other respect impair the public health, safety, comfort, morals, and welfare of the citizens of the city.

NOW THEREFORE BE IT RESOLVED that \_\_\_\_\_ motioned to **approve/deny** the request to variance Section 154.101(D)(2)(5) maximum sign face area (number of panels), minimum setback, and maximum height to allow the replacement of the sign panels on the existing high-rise pole sign at 900 Scott Drive (along I-75). The motion was seconded by \_\_\_\_\_ and the request was \_\_\_\_\_ **approved/denied** with a vote of \_\_\_\_\_ as recorded below.

RESOLUTION No. BZA 17-10

---

	AYE	NAY	ABSTAIN	ABSENT
Mr. Shawn Hicks	<input type="checkbox"/>	<input type="checkbox"/>	<input type="checkbox"/>	<input type="checkbox"/>
Mr. Pat Jenkins	<input type="checkbox"/>	<input type="checkbox"/>	<input type="checkbox"/>	<input type="checkbox"/>
Mr. Daniel Patrizio	<input type="checkbox"/>	<input type="checkbox"/>	<input type="checkbox"/>	<input type="checkbox"/>
Mr. Steve Reindel	<input type="checkbox"/>	<input type="checkbox"/>	<input type="checkbox"/>	<input type="checkbox"/>
Mr. Mark Spoltman	<input type="checkbox"/>	<input type="checkbox"/>	<input type="checkbox"/>	<input type="checkbox"/>



## PLANNING AND ZONING

Christopher W. Schmiesing – City Planner  
201 West Water Street • Piqua, Ohio 45356  
(937) 778-2049 • FAX (937) 778-5165  
E-Mail: cschmiesing@piquaoh.org

### STAFF REPORT

Date: November 11, 2010  
To: Board of Zoning Appeals Members  
From: Chris Schmiesing, City Planner  
Subject: BZA Resolution 17-10

### GENERAL INFORMATION

Applicant: National Illumination and Sign Corporation  
Owner: Emro Marketing Company  
Location: 900 Scott Drive  
Zoning: B (General Business)  
Land Use  
Existing: High Rise Sign  
Proposed: High Rise Sign  
Request: A petition to variance section 154.101(D)(2)(5) minimum setback and maximum secondary image allowance to allow the replacement of the sign cabinets/panels on the existing high-rise pole sign.

### DISCUSSION/FINDINGS

The proposed variance if approved will allow for the replacement of the existing sign cabinets and panels, which have a combined total square footage of 258 square feet, with two new sign cabinets and panels that have a combined total square footage equal to the code maximum for this sign type, 200 square feet. The existing sign structure has a setback of 5 feet to the nearest lot line and the code required minimum setback is 20 feet. The proposed sign cabinet/panel results in a primary image to secondary image ratio of 60/40.

The zoning code includes sections outlining the powers of the Board of Zoning Appeal's relative to variances and the determinations to be made prior to taking official action in a specific case. The following highlights each of the criteria described in those sections and provides staff's analysis of how this request measures up to those standards.

Section 154.142(C)(2) states, "Powers relative to variances. To hear and decide upon petitions for variances and, subject to the conditions and safeguards deemed appropriate by the Board, *to vary the strict application* of the height, area, setback, or parking requirements to the extent necessary **to permit the owner a reasonable use of the land in those specified instances where there are peculiar exceptions, and unusual circumstances in connection with a specific parcel of land, which circumstances are not generally found within the locality or neighborhood concerned.** Prior to taking action on a

## STAFF REPORT

Date: November 11, 2010  
Subject: BZA Resolution 17-10

variance request, the Board may hold a public hearing. Any variance granted by the Board shall become void if within one year on the date of passage, a building permit has not been issued and construction has not been initiated. "

Is this request necessary to permit the owner a reasonable use of the land?

- and -

Is this request justified due to peculiar exceptions and unusual circumstances found at this location that are not generally found within the neighborhood concerned?

*Staff Analysis: The existing high-rise sign cabinet/panel is located within a small valley with a densely forested wooded area to the north that partially obscures the view of the sign. The variance is necessitated due to the proposed alteration of an existing non-conforming sign; however, the improvements include replacing an existing sign cabinet and no alterations to the sign support structure. The sign has existed at this location for a number of years with no reported problems or issues, and aside from the non-standard elements reported herein, the sign structure conforms to the adopted community standards in all other regards. Therefore, it is staff's opinion that the setback variance as requested will allow for a reasonable use of the land.*

Section 154.142(D)(1) states, "Official Action. In exercising the above-mentioned jurisdiction, the Board of Zoning Appeals may reverse, affirm, or modify the order, requirement, decision, or determination appealed and may make any decision as ought to be made. In considering all appeals and petitions within its jurisdiction under this chapter, the Board shall, before making any finding in a specific case, first determine that the proposed change will not constitute a change in the district map and will not impair an adequate supply of light and air to adjacent property, or increase the congestion in public streets, or increase the public danger of fire and safety, or materially diminish or impair established property values within the surrounding area, or in any other respect impair the public health, safety, comfort, morals, and welfare of the citizens of the city. In making a determination, the Board may request information and recommendations from any department of the city."

Will the request constitute a change in the district map?

*Staff Analysis: This request will not require a change in the zoning map.*

Will this request impair an adequate supply of light and air to adjacent property?

*Staff Analysis: It is unlikely that the proposed construction will impair the supply of light and air to adjacent property.*

Will this request increase the congestion in public streets?

*Staff Analysis: It is unlikely that the proposed construction will increase the congestion in the public streets.*

## STAFF REPORT

Date: November 11, 2010  
Subject: BZA Resolution 17-10

Will this request increase the public danger of fire and safety?

*Staff Analysis: It is unlikely that the proposed construction will increase the public danger of fire and safety.*

Will this request materially diminish or impair established property values within the surrounding area? And, will this request in any other respect impair the public health, safety, comfort, morals, and welfare of the citizens of the city?

*Staff Analysis: It is unlikely that the proposed construction will impair established property values, public health, safety, comfort, morals, or the welfare of the neighborhood, community, or citizens.*

### CONCLUSION

The proposed sign cabinet/panel replacement will result in a significant upgrade to the existing improvements. While it is not practical to bring the sign setback into compliance with the current standards, the applicant has made a genuine effort to eliminate existing non-standard conditions and conform to the adopted community standards where possible. This includes reducing the existing area of the sign to conform to the allowable sign area and achieving a higher degree of conformance with the 75/25 image ratio.

Based upon the information provided, it is staff's conclusion that authorizing the proposed variance...

- will yield the property owner a reasonable use of the property
- will not result in a substantial deviation from the code requirements
- will not substantially alter the character of the neighborhood or be a detriment to the adjoining properties
- will not adversely affect the delivery of government services
- will not relieve the property owner from conforming to all other applicable standards
- will solve a problem that can not be remedied by other means
- will preserve the spirit and intent of the zoning requirements and serve substantial justice with reference to the circumstances and conditions known to exist within the neighborhood concerned.

### RECOMMENDATION

Staff recommends that the Board of Zoning Appeals **approve** the requested variance.

**STAFF REPORT**

Date: November 11, 2010  
Subject: BZA Resolution 17-10

**VICINITY MAP**

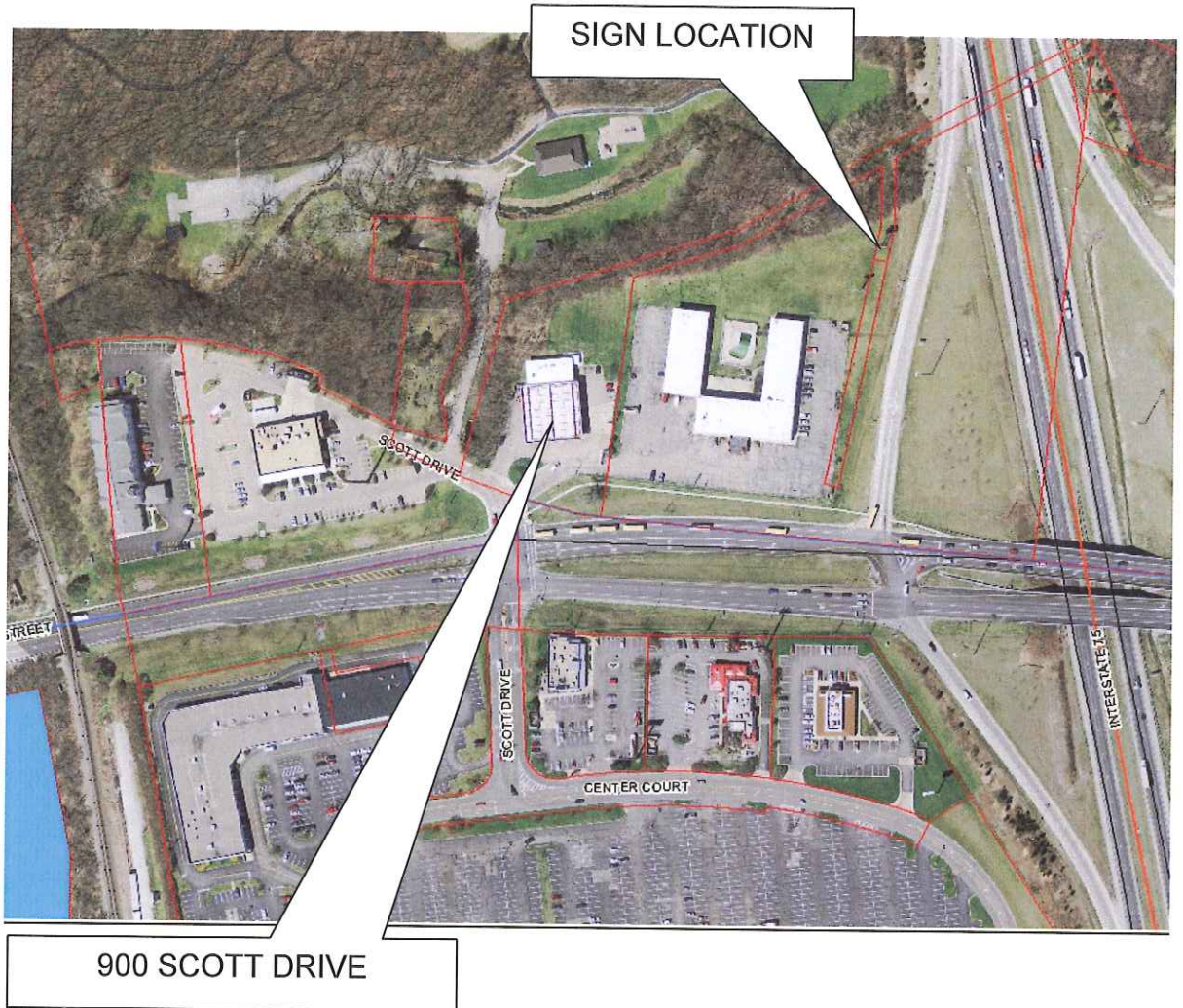

17-10

BOARD OF ZONING APPEALS

APPLICATION REQUESTING A ZONING VARIANCE

-PLEASE TYPE OR PRINT-

APPLICANT NAME Jim Bond / National Illumination & Sign  
APPLICANT ADDRESS 6525 Angola Rd.  
CITY Holland STATE OH ZIP 43528  
PHONE ( 888 ) 731 - 6122  
LEGAL INTEREST OF APPLICANT Agent to the owner

OWNER NAME Marathon Oil LLC  
BUSINESS NAME \_\_\_\_\_  
OWNER ADDRESS 539 S. Main St.  
CITY Findlay STATE OH ZIP \_\_\_\_\_  
PHONE ( 419 ) 422 - 2121

PROPERTY LOCATION WHERE VARIANCE IS BEING REQUESTED  
STREET ADDRESS 900 Scott Dr.  
CITY Piqua STATE Ohio ZIP 45356  
LOT NUMBER \_\_\_\_\_ ZONING DESIGNATION \_\_\_\_\_

TYPE OF VARIANCE BEING REQUESTED -(CIRCLE ONE) ZONING -OR- SIGN

-CHECK ALL BOXES THAT APPLY-

- ZONING ENFORCEMENT APPEAL
- SPECIAL DRIVEWAY
- HEIGHT VARIANCE
- SETBACK VARIANCE
- AREA VARIANCE
- PARKING VARIANCE
- ZONING MAP BOUNDARY LINE
- OTHER

BRIEFLY DESCRIBE VARIANCE REQUEST existing hi-rise sign is non-conforming to setback specifications.

I hereby certify that the proposed request is authorized by the owner of record and agree to conform to all applicable laws of the City of Piqua, Ohio.

SIGNATURE OF OWNER see letter of authorization DATE \_\_\_\_\_

SIGNATURE OF APPLICANT James Bond DATE 11/04/10

NOTE - BOTH OWNER AND APPLICANT DATED SIGNATURES IN INK REQUIRED TO PROCESS REQUEST

\*\*\*\*\*OFFICE USE ONLY\*\*\*\*\*

\$25.00 FEE PAID - 25.00 RECEIVED BY - B. Cool

RECEIPT No. - 194934 DATE - 11-5-10



---

Speedway SuperAmerica LLC

**Speedway Office**  
P.O. Box 1500  
Springfield, OH 45501  
Telephone 937-864-3000

Date: November 4, 2010

City of Piqua  
201 W Water Street  
Piqua, Ohio 45356

**RE: Variance Application**  
**Speedway 5243**  
**900 Scott Drive**  
**Piqua, Ohio 45356**

Dear City of Piqua Planning and Zoning Department:

Speedway SuperAmerica hereby authorizes National Illumination & Sign Corp. to act in our behalf in regards to the variance application submitted and upcoming zoning meeting.

Sincerely,

A handwritten signature in black ink, appearing to read "Adam Campbell", written over a horizontal line.

Adam Campbell  
Construction Specialist



PHONE (419)866-1666  
FAX (419)866-5731  
TOLL FREE (888)731-6122

*The Lighting Maintenance Specialists*

November 03, 2010

City of Piqua  
Board of Zoning Appeals  
201 W. Water St.  
Piqua, OH 45356

Re: Speedway #5243  
900 Scott Dr.  
Piqua, OH 45356

Dear Zoning Board Members,

Speedway stations nationwide are in the process of replacing their existing, manually changeable gas price displays with modern LED style displays, this includes hi-rise structures like the one presented before you now.

After having worked with your City Planner, Mr. Schmiesing as well as the Speedway representative in charge of the project and the sign manufacturer, we have all come to an agreeable option that incorporates the needs of all parties without sacrificing the sign's safety, function and aesthetics.

We come before the board because, though we were able to satisfy a majority of the code requirements, there remains two specific items that require your consent. They are as follows:

1) Minimum setback is 20 feet from the property line. The existing sign's setback is approximately 5 feet behind the property line. Though, to be considered, the sign is completely surrounded by a large uninhabited expanse of grass and trees, far greater than the 20 foot code recommendation.

2) The code calls for a sign cabinet ratio of 25/75 for a two cabinet system. After diligent negotiation, we were able to meet the allowable 200 square foot combined area, but the cabinet ratio is close to 60/40. This will keep the numerals large enough to read from the highway while maintaining a legible logo, also readable from a safe distance. To meet code requirement, we are dropping the current sign face area from 258 square feet down to the acceptable 200 square feet, nearly 60 square feet less than what is currently up there.

**Safety:**

These LED gas price displays ("pricers") use remote frequencies, controlled from within the safety of the sales office. This prevents any hazards that might be faced going outside in all weather conditions and fiddling with a cable/pully system to change the price of gas (practically daily these days). Hi-rise signs make the trek more daunting, considering the distance out to the sign and back. Imagine walking through 2 feet of snow in a field to change the sign's price.

LED pricers are legible at greater distances, thus increasing vehicular safety. Distraction is kept at bay due to an automatic dimmer that reduces the brightness at night for safe visibility, while brightened during the day to compete with the surrounding natural light.

Speedway has thus decided to invest further in their locations in order to ensure safer environments, not only for their employees, but for the surrounding community as well.

**Aesthetics:**

Besides safety, another great plus for the community is the sheer aesthetic appeal that an LED pricer can provide. When compared side by side, one cannot deny the clean look of an LED pricer when compared to its predecessor. We submit to you the attached drawing and ask you to make your own conclusions.

Thank you for your consideration in this matter. I look forward to discuss any questions you may have, prior to or during the variance meeting.

Respectfully,

Neil Jeakle  
Vice President  
National Illumination & Sign Corp.



EXISTING SIGN WITH  
OLD STYLE FLIPPER PRICER

SCOPE OF WORK:  
REMOVE AND DISPOSE OF OLD FLIPPER PRICE FACES.  
INSTALL LED PRICE FACES.  
CONNECT TO EXISTING ELECTRICAL CIRCUIT.

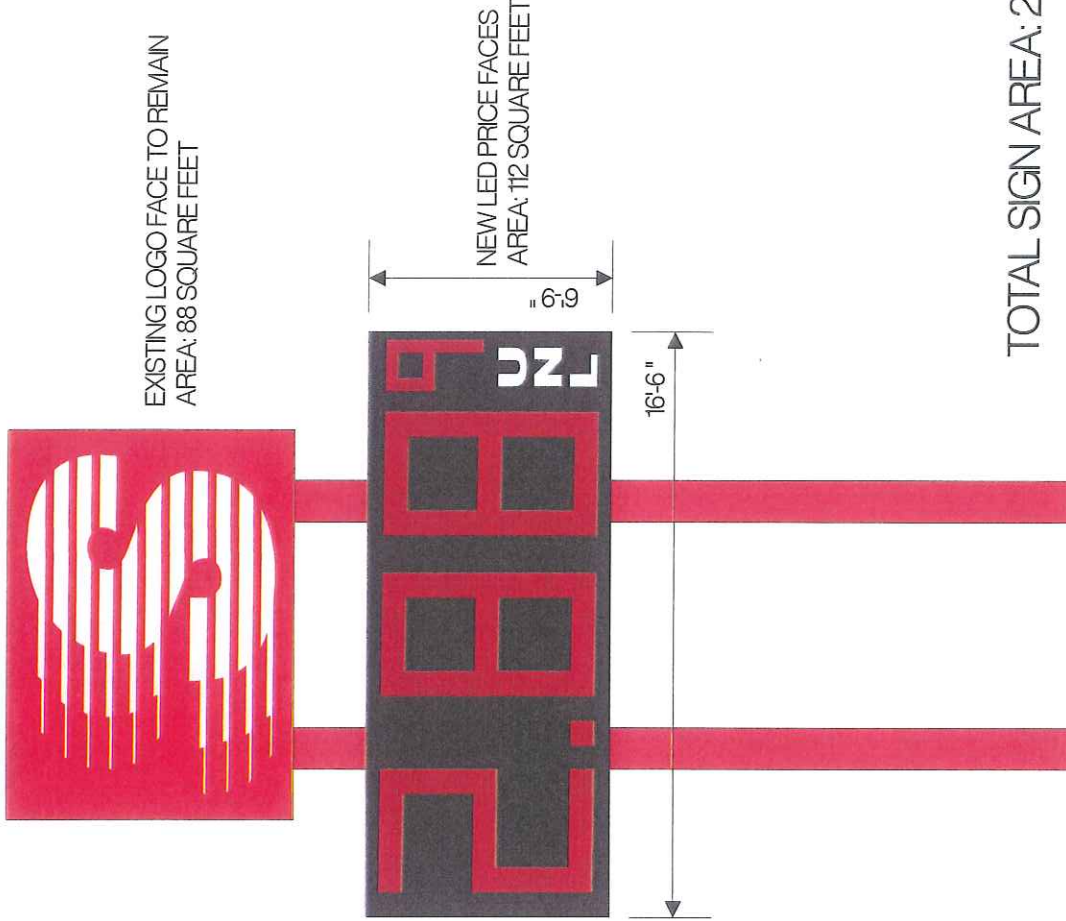

TOTAL SIGN AREA: 200 SQ. FT

**National**  
ILLUMINATION & SIGN CORPORATION  
P.O. BOX 565 / 6525 ANGOLA RD.  
HOLLAND, OHIO 43528  
PHONE: (419) 866-1818 FAX: (419) 866-4731  
E-MAIL: NISCORP@SBCCOLBAL.NET

THIS RENDERING WILL REMAIN THE EXCLUSIVE PROPERTY OF NATIONAL ILLUMINATION & SIGN CORPORATION AND IS COPYRIGHTED PER THE EXISTING LAWS OF THE UNITED STATES. IT SHALL NOT BE REPRODUCED, ALTERED, OR SHOWN WITHOUT THE WRITTEN CONSENT OF NATIONAL ILLUMINATION & SIGN CORPORATION. NATIONAL ILLUMINATION & SIGN CORPORATION RESERVES THE RIGHT TO PUBLISH ARTWORK, LOGOS, AND COMPLETION PHOTOS USING PRINTED AND ELECTRONIC MEDIA FOR NATIONAL'S ADVERTISING PURPOSES.

Project Name : SPEEDWAY #5243  
Address : 900 SCOTT DR.  
Approval ( Purchaser ) : \_\_\_\_\_  
Approval Leasor / Agent ) : \_\_\_\_\_

City: PIQUA  
State: OH  
Date: \_\_\_\_\_  
Date: \_\_\_\_\_

Salesman: GNU  
Drawing No.: 110310-1  
Scale: 3/16" = 1'  
Designer: JB  
Date: NOVEMBER 03, 2010



© 2010 Microsoft Corporation. All rights reserved. Microsoft, Windows, and Windows Live are either registered trademarks or trademarks of Microsoft Corporation in the United States and/or other countries.

STRAIGHT DISTANCE OF 600 FEET (2 FOOTBALL FIELDS) BETWEEN THE SPEEDWAY STATION AND THE HI RISE SIGN.



PO. BOX 540 / 6025 AVONDA RD.  
 HOLLAND, OHIO 43023  
 PHONE: 614.835.9771  
 E-MAIL: INFO@NATIONALSIGN.COM

THIS DESIGN WILL REMAIN THE EXCLUSIVE PROPERTY OF NATIONAL ILLUMINATIONS & SIGN CORPORATION. NO PART OF THIS DESIGN, INCLUDING BUT NOT LIMITED TO, THE DESIGN, CONCEPTS, DRAWINGS, OR ANY OTHER INFORMATION, SHALL BE REPRODUCED, ALTERED, OR SHOWN WITHOUT THE WRITTEN CONSENT OF NATIONAL ILLUMINATIONS & SIGN CORPORATION. NATIONAL ILLUMINATIONS & SIGN CORPORATION IS NOT RESPONSIBLE FOR ANY DAMAGE TO PROPERTY, PERSONS, OR ANY OTHER INFORMATION, INCLUDING BUT NOT LIMITED TO, THE DESIGN, CONCEPTS, DRAWINGS, OR ANY OTHER INFORMATION, ARISING FROM THE USE OF THIS DESIGN. ALL RIGHTS RESERVED. PHOTOGRAPHY BY NATIONAL ILLUMINATIONS & SIGN CORPORATION FOR NATIONALS ADVERTISING PURPOSES.

Project Name: SPEEDWAY #243  
 Address: 900 SCOTT DR.  
 Approval ( Purchaser ): \_\_\_\_\_  
 Approval Leasor ( Agent ) : \_\_\_\_\_

City: Piqua State: OH Date: \_\_\_\_\_  
 Designer: JBS Date: \_\_\_\_\_

Salesman: GUY Drawing No: SATELITE Scale: NTS Date: NOVEMBER 03, 2010

**RESOLUTION No. BZA 18-10**

WHEREAS, Milan Desai, 1580 Cheshire Rd., Apt. 9B, Troy, Ohio owner of the Subway located at 1300 E. Ash St., Piqua, Ohio being in a district zoned B (General Business) has filed a petition to variance Section 154.102 (D)(2)(a)(1) maximum number of primary signs at the property located at 1300 E. Ash St., Piqua, Ohio.

**§ 154.102 PERMANENT; ATTACHED SIGNS.**

(D) *Other regulations.*

(2) *Number of signs.*

(a) The maximum allowable number of primary permanent attached signs shall be as follows:

1. One primary permanent attached sign shall be permitted on each building elevation facing a street, parking lot, drive through lane, or service drive on the same lot, provided a public entrance or service window serving the business establishment to which the sign is accessory exist on the same building elevation to which the sign will be affixed, and subject to the general requirements established by this section of the code, provided no primary permanent attached signs shall be permitted when a nonconforming, abandon or obsolete permanent detached sign or permanent attached sign exist on the same lot.

WHEREAS, the Board of Zoning Appeals has considered whether the variance requested:

- Is necessary to permits the owner a reasonable use of the land.
- Is justified due to peculiar exceptions and unusual circumstances found at this location that are not generally found within the neighborhood concerned.
- Will constitute a change in the district map
- Will impair an adequate supply of light and air to adjacent property.
- Will increase the congestion in public streets.
- Will increase the public danger of fire and safety.
- Will materially diminish or impair established property values within the surrounding area.
- Will in any other respect impair the public health, safety, comfort, morals, and welfare of the citizens of the city.

NOW THEREFORE BE IT RESOLVED that \_\_\_\_\_ motioned to **approve/deny** the request to variance Section . 154.102 (D)(2)(a)(1) maximum number of primary signs at the property located at 1300 E. Ash St., Piqua, Ohio The motion was seconded by \_\_\_\_\_ and the request was \_\_\_\_\_ **approved/denied** with a vote of \_\_\_\_\_ as recorded below.

RESOLUTION No. BZA 18-10

---

	AYE	NAY	ABSTAIN	ABSENT
Mr. Shawn Hicks	<input type="checkbox"/>	<input type="checkbox"/>	<input type="checkbox"/>	<input type="checkbox"/>
Mr. Pat Jenkins	<input type="checkbox"/>	<input type="checkbox"/>	<input type="checkbox"/>	<input type="checkbox"/>
Mr. Daniel Patrizio	<input type="checkbox"/>	<input type="checkbox"/>	<input type="checkbox"/>	<input type="checkbox"/>
Mr. Steve Reindel	<input type="checkbox"/>	<input type="checkbox"/>	<input type="checkbox"/>	<input type="checkbox"/>
Mr. Mark Spoltman	<input type="checkbox"/>	<input type="checkbox"/>	<input type="checkbox"/>	<input type="checkbox"/>



## PLANNING AND ZONING

Christopher W. Schmiesing – City Planner  
201 West Water Street • Piqua, Ohio 45356  
(937) 778-2049 • FAX (937) 778-5165  
E-Mail: cschmiesing@piquaoh.org

### STAFF REPORT

Date: November 11, 2010  
To: Board of Zoning Appeals Members  
From: Chris Schmiesing, City Planner  
Subject: BZA Resolution 18-10

### GENERAL INFORMATION

Applicant: Milan Desai  
Owner: Milan Desai  
Location: 1300 E. Ash Street  
Zoning: B (General Business)  
Land Use  
Existing: General Merchandise/Restaurant Standard  
Proposed: General Merchandise/Restaurant Standard  
Request: A petition to variance section 154.102(D)(2)(a)(1) maximum number of primary wall signs.

### DISCUSSION/FINDINGS

The proposed variance if approved will allow for the installation of an additional primary wall sign at this location to advertise for the Subway store located inside of the Wal-Mart building. The BZA previously authorized a variance to allow for the wall signage currently found at this location which exceeds the maximum number of allowable wall signs as permitted by code.

The zoning code includes sections outlining the powers of the Board of Zoning Appeal's relative to variances and the determinations to be made prior to taking official action in a specific case. The following highlights each of the criteria described in those sections and provides staff's analysis of how this request measures up to those standards.

Section 154.142(C)(2) states, "Powers relative to variances. To hear and decide upon petitions for variances and, subject to the conditions and safeguards deemed appropriate by the Board, *to vary the strict application* of the height, area, setback, or parking requirements to the extent necessary **to permit the owner a reasonable use of the land in those specified instances where there are peculiar exceptions, and unusual circumstances in connection with a specific parcel of land, which circumstances are not generally found within the locality or neighborhood concerned.** Prior to taking action on a variance request, the Board may hold a public hearing. Any variance granted by the Board

## STAFF REPORT

Date: November 11, 2010  
Subject: BZA Resolution 18-10

shall become void if within one year on the date of passage, a building permit has not been issued and construction has not been initiated. "

Is this request necessary to permit the owner a reasonable use of the land?

- and -

Is this request justified due to peculiar exceptions and unusual circumstances found at this location that are not generally found within the neighborhood concerned?

*Staff Analysis: The proposed sign would advertise for a business located inside of the existing Wal-Mart building that otherwise has no outdoor advertising at this location. The wall sign package previously presented to the BZA for consideration included an exterior wall sign for the Unity National tenant space located inside the building; however, the request did not include a sign allowance for the Subway tenancy. Therefore, it is staff's opinion that the setback variance as requested will allow for a reasonable use of the land.*

Section 154.142(D)(1) states, "Official Action. In exercising the above-mentioned jurisdiction, the Board of Zoning Appeals may reverse, affirm, or modify the order, requirement, decision, or determination appealed and may make any decision as ought to be made. In considering all appeals and petitions within its jurisdiction under this chapter, the Board shall, before making any finding in a specific case, first determine that the proposed change will not constitute a change in the district map and will not impair an adequate supply of light and air to adjacent property, or increase the congestion in public streets, or increase the public danger of fire and safety, or materially diminish or impair established property values within the surrounding area, or in any other respect impair the public health, safety, comfort, morals, and welfare of the citizens of the city. In making a determination, the Board may request information and recommendations from any department of the city."

Will the request constitute a change in the district map?

*Staff Analysis: This request will not require a change in the zoning map.*

Will this request impair an adequate supply of light and air to adjacent property?

*Staff Analysis: It is unlikely that the proposed construction will impair the supply of light and air to adjacent property.*

Will this request increase the congestion in public streets?

*Staff Analysis: It is unlikely that the proposed construction will increase the congestion in the public streets.*

Will this request increase the public danger of fire and safety?

*Staff Analysis: It is unlikely that the proposed construction will increase the public danger of fire and safety.*

## STAFF REPORT

Date: November 11, 2010  
Subject: BZA Resolution 18-10

Will this request materially diminish or impair established property values within the surrounding area? And, will this request in any other respect impair the public health, safety, comfort, morals, and welfare of the citizens of the city?

*Staff Analysis: It is unlikely that the proposed construction will impair established property values, public health, safety, comfort, morals, or the welfare of the neighborhood, community, or citizens.*

### CONCLUSION

As indicated by the BZA's prior authorization for the number of wall signs permissible at this location, the scale of this building can easily accommodate the proposed sign in addition to the existing signage without the exterior signage at this location becoming overwhelming. While the placement of the sign is somewhat removed from the actual tenant location inside the building it is probably as reasonable a location as any given the existing signage already found on the building façade.

Based upon the information provided, it is staff's conclusion that authorizing the proposed variance...

- will yield the property owner a reasonable use of the property
- will not result in a substantial deviation from the code requirements
- will not substantially alter the character of the neighborhood or be a detriment to the adjoining properties
- will not adversely affect the delivery of government services
- will not relieve the property owner from conforming to all other applicable standards
- will solve a problem that can not be remedied by other means
- will preserve the spirit and intent of the zoning requirements and serve substantial justice with reference to the circumstances and conditions known to exist within the neighborhood concerned.

### RECOMMENDATION

Staff recommends that the Board of Zoning Appeals **approve** the requested variance.

STAFF REPORT

Date: November 11, 2010  
Subject: BZA Resolution 18-10

VICINITY MAP



1300 E. ASH ST

BOARD OF ZONING APPEALS

18-10

APPLICATION REQUESTING A ZONING VARIANCE

-PLEASE TYPE OR PRINT-

APPLICANT NAME MILAN DESAI  
APPLICANT ADDRESS 1580 CHESHIRE RD. APT- 9B  
CITY TROY STATE OH ZIP 45373

PHONE (630) 808-8299

LEGAL INTEREST OF APPLICANT Mount the Exterior Building Sign

OWNER NAME AS ABOVE

BUSINESS NAME \_\_\_\_\_

OWNER ADDRESS \_\_\_\_\_

CITY \_\_\_\_\_ STATE \_\_\_\_\_ ZIP \_\_\_\_\_

PHONE (\_\_\_\_) \_\_\_\_\_ - \_\_\_\_\_

PROPERTY LOCATION WHERE VARIANCE IS BEING REQUESTED

STREET ADDRESS 1300 E. ASH ST. (WAL-MART)

CITY Piqua STATE Ohio ZIP 45356

LOT NUMBER \_\_\_\_\_ ZONING DESIGNATION \_\_\_\_\_

TYPE OF VARIANCE BEING REQUESTED - (CIRCLE ONE) ZONING -OR- SIGN

-CHECK ALL BOXES THAT APPLY-

- ZONING ENFORCEMENT APPEAL
- SPECIAL DRIVEWAY
- HEIGHT VARIANCE
- SETBACK VARIANCE
- AREA VARIANCE
- PARKING VARIANCE
- ZONING MAP BOUNDARY LINE
- OTHER

BRIEFLY DESCRIBE VARIANCE REQUEST Mount the exterior

Building Sign or Logo For Subway inside Wal-Mart

I hereby certify that the proposed request is authorized by the owner of record and agree to conform to all applicable laws of the City of Piqua, Ohio.

x SIGNATURE OF OWNER  DATE 10/21/2010

SIGNATURE OF APPLICANT  DATE 10/21/2010

NOTE - BOTH OWNER AND APPLICANT DATED SIGNATURES IN INK REQUIRED TO PROCESS REQUEST

\*\*\*\*\*OFFICE USE ONLY\*\*\*\*\*

x \$25.00 FEE PAID - 25.00 RECEIVED BY - B Cool

RECEIPT No. - 194936 DATE - 11-8-10

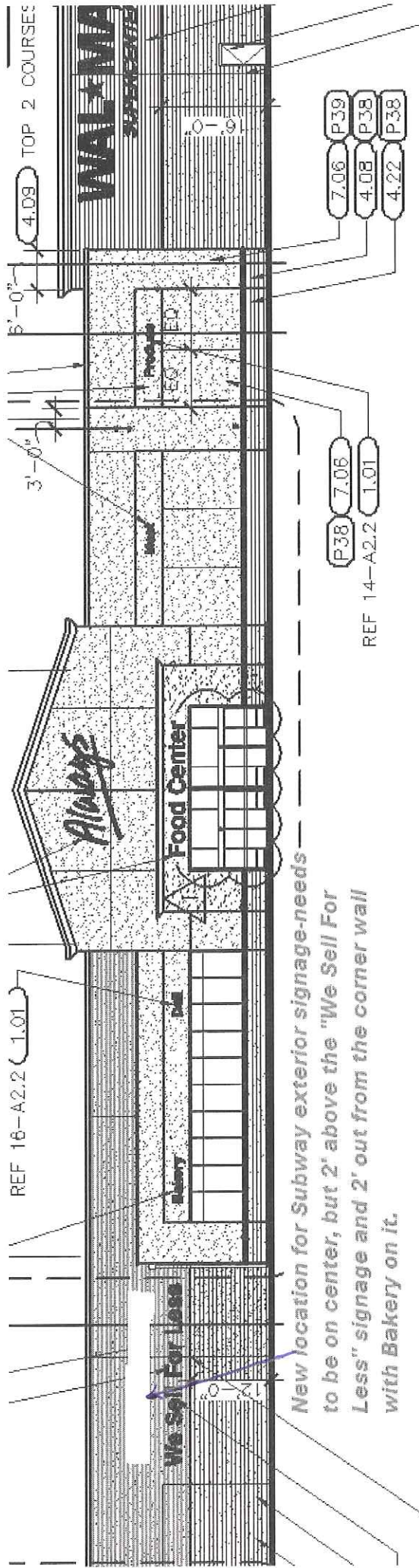

*New location for Subway exterior signage-needs to be on center, but 2' above the "We Sell For Less" signage and 2' out from the corner wall with Bakery on it.*



# LED CONTOUR SIGNS

## STANDARD FEATURES

- Single face SUBWAY® logo sign
- Face is .177 clear poly w/ embossed letters, screened 2nd surface; Cap-over design
- SUB - white letters; WAY - PMS 109 yellow letters
- PMS 554 Dk.Green contour shape background; Green background is opaque
- .063 alum. black exterior return; .063 alum. back: White interior

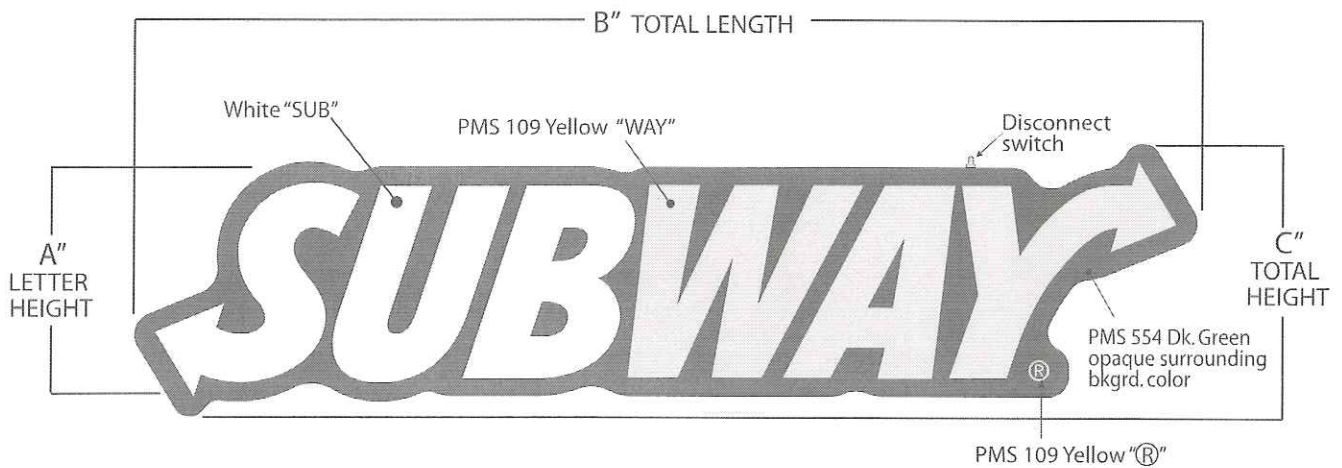

## LED CONTOUR SIGNS

Nominal Size	A	B	C	D (depth)	Area (sq ft)	E Number	ILLUMINATION
11.5" Letter Ht.*	11-1/2"	67"	17-7/8"	5"	8.31	E003048B	32 Nichia LED's total; 5 drivers; 1- 96 watt power supply
18" Letter Ht.	18"	87"	22-5/8"	5"	13.66	E003049B	34 Nichia LED's total; 5 drivers; 1- 96 watt power supply
22" Letter Ht.	21-5/8"	104"	27"	5"	19.50	E004142B	49 Nichia LED's total; 7 drivers; 1- 96 watt power supply
24" Letter Ht.	24"	116"	30"	5"	24.16	E003050B	51 Nichia LED's total; 8 drivers; 1- 96 watt power supply
30" Letter Ht.	30"	144"	37-1/2"	5"	37.5	E003051B	68 Nichia LED's total; 10 drivers; 1- 96 watt power supply
36" Letter Ht.	36"	174"	45"	5"	54.37	E003052B	68 Nichia LED's total; 10 drivers; 1- 96 watt power supply

\*NOTE: The 11.5" Contour Sign is designed for indoor use only

The 22" contour sign is designed for outdoor use only

\*Warranty: Three year parts

\* Signs must be inspected before installation  
 Everbrite must be notified within 15 days of delivery of any damage.  
 Notify Everbrite and the carrier immediately. Do not install the sign.



**RESOLUTION No. BZA 19-10**

WHEREAS, LeVeck Lighting on behalf of Home Depot #3862 located at 1200 East Ash Street, Piqua, Ohio being in a district zoned B (General Business) has filed a petition to variance Section 154.102 (C)(1) maximum area for a wall sign at 1200 E. Ash Street, Piqua, Ohio.

**§ 154.102 PERMANENT; ATTACHED SIGNS.**

(C) *Height, area, and setback regulations.*

(1) General requirements for primary permanent detached signs.

Sign Type	Maximum Height	Minimum Height	Maximum Sign Area	Maximum Projection from Structure Face into Required Minimum Setback Area
Awning sign; canopy (attached) sign	20 feet	8 feet	1 sq. foot per lineal foot of the width of the awning face to which the sign will be attached, not to exceed 50 sq. feet	6 feet
Projecting sign	30 feet	8 feet	1 sq. foot per lineal foot of the width of the structure to which the sign will be attached, not to exceed 50 sq. feet	4 feet
Wall or fascia sign on a building elevation located 0 to 49 feet from the lot line	20 feet	8 feet	1.5 sq. feet per lineal foot of the structure face to which the sign will be attached, not to exceed 50 sq. feet	2 feet
Wall or fascia sign on a building elevation located 50 to 149 feet from the lot line	30 feet	12 feet	2 sq. feet per lineal foot of the structure face to which the sign will be attached, not to exceed 100 sq. feet	2 feet
Wall or fascia sign on a building elevation located 150 feet or more from the lot line	No maximum height	20 feet	3 sq. feet per lineal foot of the structure face to which the sign will be attached, not to exceed 150 sq. feet	2 feet
Window sign	First floor windows only	0 feet	50% of the window surface, not to exceed 10 sq. feet	0 feet

Note: The portion of the structure face width eligible for inclusion when calculating the allowable area of wall or fascia sign or a projecting sign shall be only that portion of the exterior structure face immediately adjacent to the interior building area occupied by the business establishment to which the sign is accessory.

**RESOLUTION No. BZA 19-10**

WHEREAS, the Board of Zoning Appeals has considered whether the variance requested:

- Is necessary to permits the owner a reasonable use of the land.
- Is justified due to peculiar exceptions and unusual circumstances found at this location that are not generally found within the neighborhood concerned.
- Will constitute a change in the district map
- Will impair an adequate supply of light and air to adjacent property.
- Will increase the congestion in public streets.
- Will increase the public danger of fire and safety.
- Will materially diminish or impair established property values within the surrounding area.
- Will in any other respect impair the public health, safety, comfort, morals, and welfare of the citizens of the city.

NOW THEREFORE BE IT RESOLVED that \_\_\_\_\_ motioned to **approve/deny** the request to variance Section 154.102 (C)(1) maximum area for a wall sign at 1200 E. Ash Street, Piqua, Ohio. The motion was seconded by \_\_\_\_\_ and the request was \_\_\_\_\_ **approved/denied** with a vote of \_\_\_\_\_ as recorded below.

---

	AYE	NAY	ABSTAIN	ABSENT
Mr. Shawn Hicks	<input type="checkbox"/>	<input type="checkbox"/>	<input type="checkbox"/>	<input type="checkbox"/>
Mr. Pat Jenkins	<input type="checkbox"/>	<input type="checkbox"/>	<input type="checkbox"/>	<input type="checkbox"/>
Mr. Daniel Patrizio	<input type="checkbox"/>	<input type="checkbox"/>	<input type="checkbox"/>	<input type="checkbox"/>
Mr. Steve Reindel	<input type="checkbox"/>	<input type="checkbox"/>	<input type="checkbox"/>	<input type="checkbox"/>
Mr. Mark Spoltman	<input type="checkbox"/>	<input type="checkbox"/>	<input type="checkbox"/>	<input type="checkbox"/>



## PLANNING AND ZONING

Christopher W. Schmiesing – City Planner  
201 West Water Street • Piqua, Ohio 45356  
(937) 778-2049 • FAX (937) 778-5165  
E-Mail: cschmiesing@piquaoh.org

### STAFF REPORT

Date: November 11, 2010  
To: Board of Zoning Appeals Members  
From: Chris Schmiesing, City Planner  
Subject: BZA Resolution 19-10

### GENERAL INFORMATION

Applicant: LeVeck  
Owner: Home Depot  
Location: 1200 E. Ash Street  
Zoning: B (General Business)  
Land Use  
Existing: General Merchandise  
Proposed: General Merchandise  
Request: A petition to variance section 154.102(C)(1) maximum area for a wall sign.

### DISCUSSION/FINDINGS

The proposed variance if approved will allow for the replacement of the existing primary wall signage, which total 464 square feet, with a new primary wall sign with a total square footage equal to 438. Although the code maximum for this sign type is 150 square feet, the BZA previously authorized a variance approving the existing signage at this location.

The zoning code includes sections outlining the powers of the Board of Zoning Appeal's relative to variances and the determinations to be made prior to taking official action in a specific case. The following highlights each of the criteria described in those sections and provides staff's analysis of how this request measures up to those standards.

Section 154.142(C)(2) states, "Powers relative to variances. To hear and decide upon petitions for variances and, subject to the conditions and safeguards deemed appropriate by the Board, *to vary the strict application* of the height, area, setback, or parking requirements to the extent necessary **to permit the owner a reasonable use of the land in those specified instances where there are peculiar exceptions, and unusual circumstances in connection with a specific parcel of land, which circumstances are not generally found within the locality or neighborhood concerned.** Prior to taking action on a variance request, the Board may hold a public hearing. Any variance granted by the Board

## STAFF REPORT

Date: November 11, 2010  
Subject: BZA Resolution 19-10

shall become void if within one year on the date of passage, a building permit has not been issued and construction has not been initiated. “

Is this request necessary to permit the owner a reasonable use of the land?

- and -

Is this request justified due to peculiar exceptions and unusual circumstances found at this location that are not generally found within the neighborhood concerned?

*Staff Analysis: The proposed sign will reduce the number of sign graphics on the façade and lessen the degree of nonconformance with the applicable standards. In light of the variance previously authorized, it is staff's opinion that the area variance as requested will allow for a reasonable use of the land.*

Section 154.142(D)(1) states, “Official Action. In exercising the above-mentioned jurisdiction, the Board of Zoning Appeals may reverse, affirm, or modify the order, requirement, decision, or determination appealed and may make any decision as ought to be made. In considering all appeals and petitions within its jurisdiction under this chapter, the Board shall, before making any finding in a specific case, first determine that the proposed change will not constitute a change in the district map and will not impair an adequate supply of light and air to adjacent property, or increase the congestion in public streets, or increase the public danger of fire and safety, or materially diminish or impair established property values within the surrounding area, or in any other respect impair the public health, safety, comfort, morals, and welfare of the citizens of the city. In making a determination, the Board may request information and recommendations from any department of the city.”

Will the request constitute a change in the district map?

*Staff Analysis: This request will not require a change in the zoning map.*

Will this request impair an adequate supply of light and air to adjacent property?

*Staff Analysis: It is unlikely that the proposed construction will impair the supply of light and air to adjacent property.*

Will this request increase the congestion in public streets?

*Staff Analysis: It is unlikely that the proposed construction will increase the congestion in the public streets.*

Will this request increase the public danger of fire and safety?

*Staff Analysis: It is unlikely that the proposed construction will increase the public danger of fire and safety.*

Will this request materially diminish or impair established property values within the surrounding area? And, will this request in any other respect impair the public health, safety, comfort, morals, and welfare of the citizens of the city?

## STAFF REPORT

Date: November 11, 2010  
Subject: BZA Resolution 19-10

*Staff Analysis: It is unlikely that the proposed construction will impair established property values, public health, safety, comfort, morals, or the welfare of the neighborhood, community, or citizens.*

### CONCLUSION

The proposed sign replacement will result in a significant upgrade to the existing improvements. While the sign will not conform to the current applicable standards, the proposed improvement does lessen the degree of the variance from what was previously authorized.

Based upon the information provided, it is staff's conclusion that authorizing the proposed variance...

- will yield the property owner a reasonable use of the property
- will not result in a substantial deviation from the code requirements
- will not substantially alter the character of the neighborhood or be a detriment to the adjoining properties
- will not adversely affect the delivery of government services
- will not relieve the property owner from conforming to all other applicable standards
- will solve a problem that can not be remedied by other means
- will preserve the spirit and intent of the zoning requirements and serve substantial justice with reference to the circumstances and conditions known to exist within the neighborhood concerned.

### RECOMMENDATION

Staff recommends that the Board of Zoning Appeals **approve** the requested variance.

**STAFF REPORT**

Date: November 11, 2010  
Subject: BZA Resolution 19-10

**VICINITY MAP**



1200 E. ASH ST

19-10

BOARD OF ZONING APPEALS

APPLICATION REQUESTING A ZONING VARIANCE

-PLEASE TYPE OR PRINT-

APPLICANT NAME Lelbeck Lighting  
APPLICANT ADDRESS 8415 State Route 202  
CITY Tipp City STATE OHIO ZIP 45371  
PHONE (937) 667-4421  
LEGAL INTEREST OF APPLICANT Contractor

OWNER NAME Home Depot  
BUSINESS NAME Home Depot # 3862  
OWNER ADDRESS 1200 East Ash St.  
CITY Piqua STATE Ohio ZIP 45356  
PHONE (937) 615-9606

PROPERTY LOCATION WHERE VARIANCE IS BEING REQUESTED  
STREET ADDRESS 1200 East Ash St.  
CITY Piqua STATE Ohio ZIP 45356  
LOT NUMBER \_\_\_\_\_ ZONING DESIGNATION \_\_\_\_\_

TYPE OF VARIANCE BEING REQUESTED -(CIRCLE ONE) ZONING -OR- SIGN

-CHECK ALL BOXES THAT APPLY-

- ZONING ENFORCEMENT APPEAL
- SPECIAL DRIVEWAY
- HEIGHT VARIANCE
- SETBACK VARIANCE
- AREA VARIANCE
- PARKING VARIANCE
- ZONING MAP BOUNDARY LINE
- OTHER

BRIEFLY DESCRIBE VARIANCE REQUEST Wall Sign Replacement

I hereby certify that the proposed request is authorized by the owner of record and agree to conform to all applicable laws of the City of Piqua, Ohio.

SIGNATURE OF OWNER \_\_\_\_\_ DATE \_\_\_\_\_

SIGNATURE OF APPLICANT MH Huber DATE 11-9-10

NOTE - BOTH OWNER AND APPLICANT DATED SIGNATURES IN INK REQUIRED TO PROCESS REQUEST

\*\*\*\*\*OFFICE USE ONLY\*\*\*\*\*

\$25.00 FEE PAID - 25.00 RECEIVED BY - B Coal

RECEIPT No. - 194937 DATE - 11-10-10  
ck# 61797

BILL OF MATERIALS

No.	QTY	DESCRIPTION	SPEC.
2	AS REQ'D	LED ALUMINUM SHEET LETTER PACK	
3	AS REQ'D	603" ALUM BLACK GLOSS FREIGHT LTR RETURN (L) WRAPPED	
4	938 FT.	ULTRA FOOTRAE	GERCKWOL6
5	12	POWER SUPPLY	CEP'S 2-60
6	96	SPLICE CONNECTORS	191600044
7	72 FT.	SUPPLY WIRE	9409
8	48	END CAPS	GERMEC.
9	AS REQ'D	1/2" LEXAN 7210 ORANGE (LTR FACE)	
10	AS REQ'D	20 AMP HORIZONTAL-UL ELECTRICAL DISCONNECT (TOGGLE SWITCH)	
11	12	3M BLACK OPAQUE VINYL FILM	
12	20	AMP HORIZONTAL-UL ELECTRICAL DISCONNECT (TOGGLE SWITCH)	
13	24	4" X 2 1/4" GALV. JUNCTION BOX, STEEL CITY # 58371.1/2	
14	AS REQ'D	1/2" DIA. FLEXIBLE UL APPROVED CONDUIT	
15	AS REQ'D	2" X 2" X 2' ALUMINUM ANGLE CLIPS 30# 6/16	
16	AS REQ'D	3/8"-16 X 1" LG. HEX HEAD BOLT W/ WASHER AND LOCKNUT	
17	AS REQ'D	3/8"-16 ALUM. RINNUIT (N.C. THREAD)	
18	AS REQ'D	U.L. LISTED CONDUIT AS PER LOCAL CODES BY OTHERS	
19	AS REQ'D	PRE-DRILLED 5/16" DRAIN HOLE W/ LIGHT Baffle MIN. 2" LETTER	
20	AS REQ'D	UNDR. U.L. AND ELECTRICAL LABEL LOCATOR	
21	AS REQ'D	#8 SS. PAN HEAD SCREWS	
22	AS REQ'D	3/8"-16 X 20 ALUMINUM THREADED ROD THRU BUILT INTO ANGLE	18/8
23	AS REQ'D	(OR BLOCKING) FOR EFS/ WOOD WALLS	
24	AS REQ'D	#5 X 3/4" ROUND WASHER HEAD PHILLIPS SCREW ZINC PLATED 2"-0"	
25	AS REQ'D	O.C. APPROX. MASTEX-CARP 40152A008 OR EQUIVALENT	
26	AS REQ'D	SILICONE CAULKING APPLIED TO ALL WALL PENETRATIONS	
27	AS REQ'D	1/8" X 1 1/2" X 1 1/2" DIP ANGLE APPROX. 6" CENTER ON CURVES	ALUM.
28	AS REQ'D	1/8" X 1 1/2" X 1 1/2" ANGLE ON STRAIGHT EDGE LETTERS (G. MERT PER LETTER)	ALUM.
29	AS REQ'D	#64 PINET POP ALUMINUM	

NOTES:  
 BIN CODES - DO NOT MIX LIGHT INTENSITY (LU) WITHIN A LETTER SET.  
 U - CONTACT [BIN] - DO NOT MIX BIN #'S WITHIN A LETTER SET.  
 X - # - DIP SWITCH # MUST MATCH BIN # OF MODULE.  
 Power Supply: CEP'S 2-60

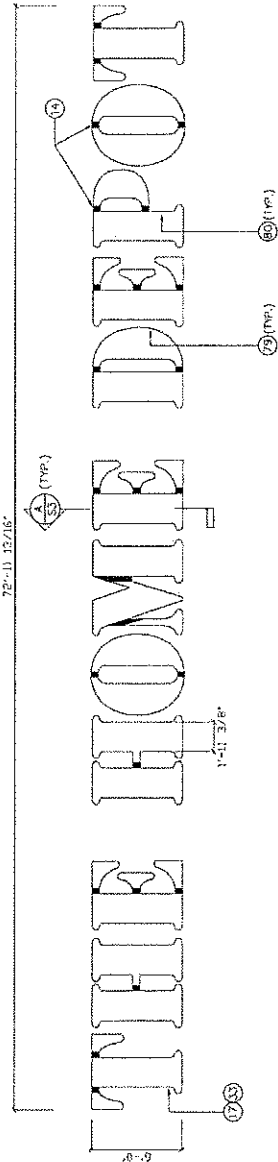
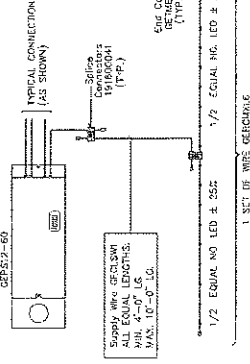

ELEVATION

SCALE 1/8"=1'-0"

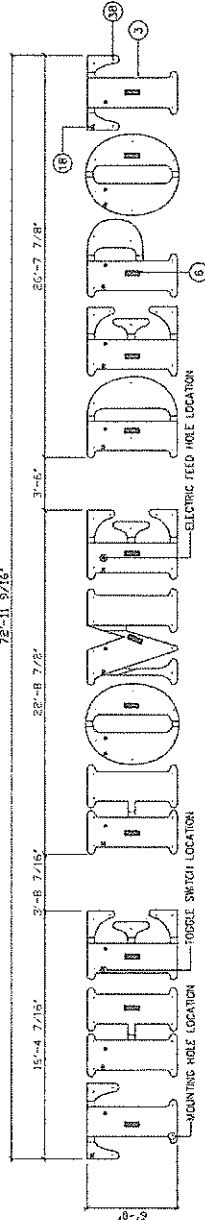

MOUNTING LOCATION

SCALE 1/8"=1'-0"

THIS SIGN TO BEAR THIS MARK

AREA/WEIGHT  
 SIGN SQUARE FOOTAGE:  
 SIGN WEIGHT:  
 SIGN WEIGHT:

THIS SIGN TO BE MOUNTED ON WHITE FOR MAXIMUM REF. ACTIVITY

THIS SIGN IS INTENDED TO BE INSTALLED IN ACCORDANCE WITH THE REQUIREMENTS OF ARTICLE 600 OF THE NATIONAL ELECTRICAL CODE AND/OR LOCAL CODES. THIS SIGN INCLUDES PROPER GROUNDING AND BONDING OF SIGN.

USE WHITE SILICONE TO CONCEAL JOINT LEAKS

WARNING: CLEANING AGENTS POLISHABLE WILL CAUSE SIGN APPEARANCE TO BE LOST. CLEAN WITH SOAP AND WATER.

TOLERANCE ± 1/16" ON ALL DIMENSIONS



1418 DEARBURST RD.  
 ELK GROVE VILLAGE  
 ILLINOIS 60007

16'-0" X 72'-11" LED CHANNEL LETTER (SELF-CONTAINED)  
 DRAWN BY: ADMAN MEHMOOD  
 DATE DRAWN: 06/23/2010  
 DRAWING SCALE: 1/8" = 1'-0"

THE HOME DEPOT  
 APPROVED BY: [Signature]  
 DATE: 08/30/10  
 FILE: HDE0086B SHEET: 1/5

DETAIL-LED CONN

SCALE: 3/4"

**Tetra® LED Systems**  
**MATERIAL ESTIMATE**  
 ESTIMATE FOR ONE SIDE OF SIGN ONLY

014159-08  
 Revision: 014159-08  
 Parent Company: THD

**MATERIAL LIST**

LED Module	GERCMXL6	636 Ft
Power Supply**	GPSP12-60 GPSP12-20	12 Ea 9 Ea
Electrical Connector	191600041	96 Ea
Supply Wire	8509	72 Ft
End Cap	GE1MCE1	48 Ea

**MATERIAL BREAKDOWN**

Part	Qty	Module	P/S
T	37	6	75.0
H	89	0	105.0
E	64	6	91.0
F	66	0	116.0
Q	58	6	117.0
N	62	6	115.0
L	46	6	93.0
D	67	6	115.0
P	46	6	93.0
S	69	6	98.0
O	58	6	117.0
I	37	6	75.0



72" @ 1"

** Power Supply Location	ILLUMINATION	Total Amps (Input)	Total Watts (System)	Area	Energy Consumption
SELF-CONTAINED	FACE or BACKLIT	10.2 Amps	339.6 Watts	242.25 Sq Ft	1.40 Watts/Sq Ft

**Tetra® LED Systems**  
 EAST CLEVELAND, OH 44112

**Lumination**  
 1418 KRAMBURST RD.  
 ELEC. GROVE VILLAGE  
 ILLINOIS 60007

**icon**  
 Identity Solutions

TECHNICAL SUPPORT: 888-684-3533  
 EMAIL: [TECHDRAWINGS@IGE.COM](mailto:TECHDRAWINGS@IGE.COM)  
 E-FAKES: 216-359-0075

1418 KRAMBURST RD.  
 ELEC. GROVE VILLAGE  
 ILLINOIS 60007

**6-0" X 72-11" LED CHANNEL LETTER (SELF-CONTAINED)**

Drawn By: BIP  
 Checked By: BIP  
 Date: 06/21/10

DRAWINGS ARE THE EXCLUSIVE PROPERTY OF IGE IDENTITY SOLUTIONS INC. ANY REUSE OR REPRODUCTION OF THESE DRAWINGS WITHOUT THE WRITTEN PERMISSION OF IGE IDENTITY SOLUTIONS IS PROHIBITED. INSTALLATION, DIMENSIONS, MATERIALS AND FINISHES SHALL BE AS SHOWN UNLESS OTHERWISE SPECIFIED. IGE IDENTITY SOLUTIONS INC. IS NOT RESPONSIBLE FOR ANY ERRORS OR OMISSIONS IN THESE DRAWINGS. IF THIS DESIGN IS USED OUTSIDE OF THE IGE COMPANY AND THE APPROVED MANUAL.

**DETAIL-LED LAYOUT**  
 SCALE: 1/2"=1'-0"

3

014159-08  
 PAGE 1 OF 1

**THE HOME DEPOT**

APPROVED BY:   
 DATE: 08/30/10  
 FILE: HDE0086B / SHEET: 2/5

LOCATION: VARIOUS  
 REQUEST No.: 59214  
 DRAWN BY: ADNAN MEHMOOD  
 DATE DRAWN: 06/23/2010  
 DRAWING SCALE: 3/76" = 1'-0"

Rev b

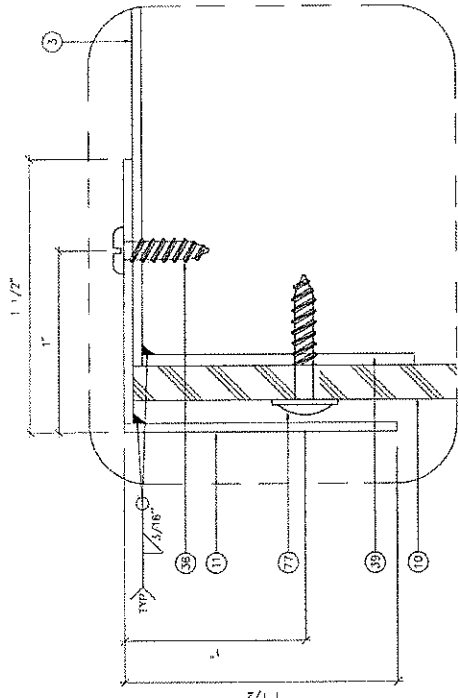

4 DETAIL  
SCALE: 3"=1'-0"

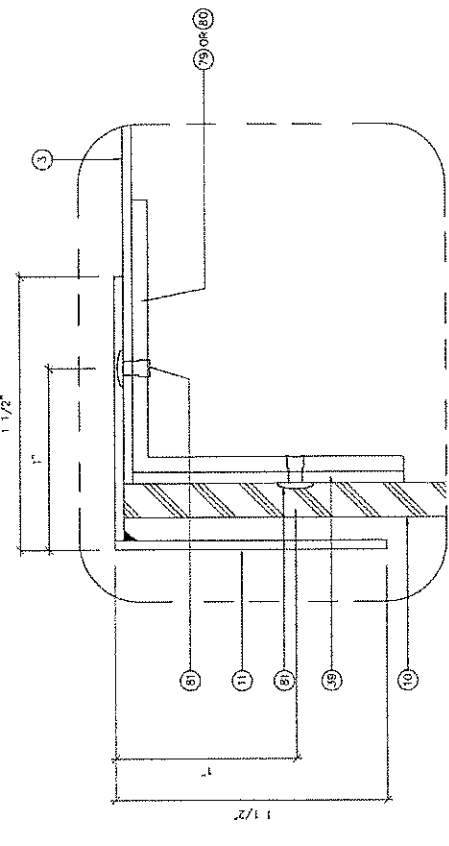

5 DETAIL WITH CLIP ANGLE  
SCALE: N.T.S.

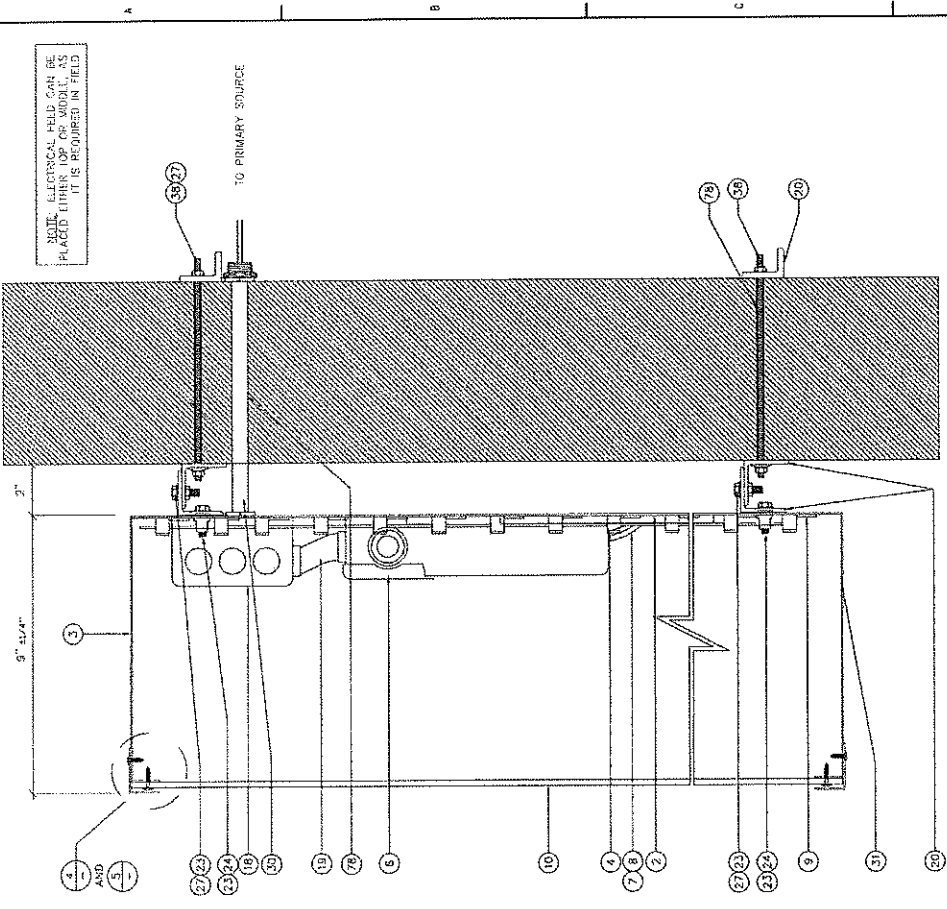

A SECTION  
SCALE: 3"=1'-0"

1416 BEMHURST RD.  
316 GROVE VILLAGE  
ILLINOIS 6007

Health Solutions

SIGN ID: 1

**6-0" X 72"-11" LED CHANNEL LETTER (SELF-CONTAINED)**

VARIOUS

LOCATION: VARIOUS

REQUEST NO.: 89214

DRAWN BY: AD'NAN METHOOD

DATE DRAWN: 06/23/2010

DRAWING SCALE: 1/1" = 1'-0"

**THE HOME DEPOT**

APPROVED BY: *[Signature]* DATE: 08/30/10

FILE: HDE0066B SHEET: 3/5





Qty: 2

Substrate 18'

Cabinet 16'- 11"

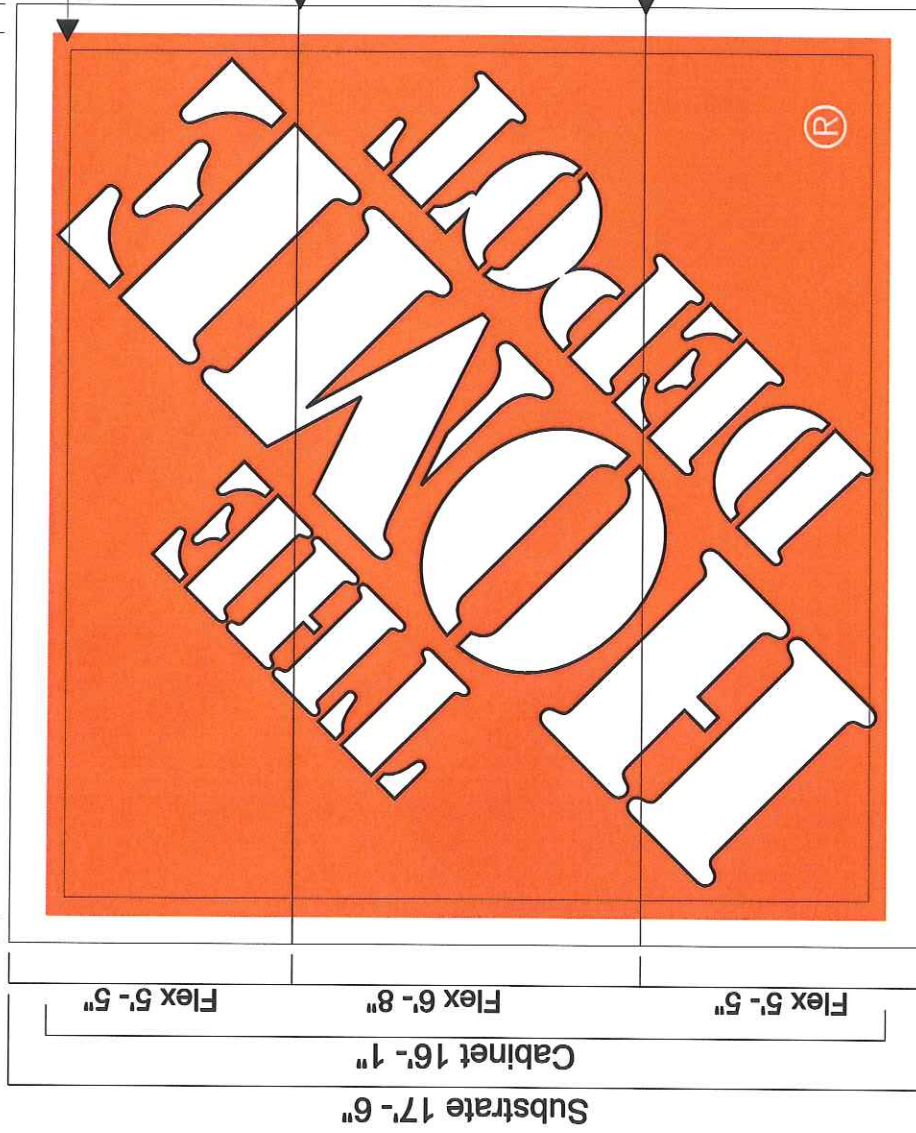

4" Retainer

Flex Seams

Flex Seams

3M Panaflex

3632-44 Orange Bkgd.

3632-22 Black 3/8" Outline



**Flex Face**

Customer:	Home Depot
Company:	Icon Identity
Address:	1418 Eimhurst Dr.
City:	Elk Grove Village
State/ZIP:	IL 60007
Phone:	
Fax:	

**Approval Signature:**

Job No.:	
Date:	11/2/2010
Order Date:	
Ship Date:	
Subcontractor:	Bill Dendy
Qty:	2
PO Number:	
Comments:	



**Z3 GRAPHICS**  
*Your Outsourcing Experts!*

Ph: 800-664-1093

Fax: 800-664-1193

**THE HOME DEPOT**

OHIO'S HOME IMPROVEMENT WAREHOUSE

